

Installation & Operating Manual

The Harman Advance Pellet Stove

HARMAN™

BUILT TO A STANDARD, NOT A PRICE



We suggest that our hearth products be installed and serviced by professionals who are certified in the U.S. by the National Fireplace Institute (NFI) as NFI Specialists.

“Ce manuel est disponible en Français sur demande”



SAFETY NOTICE

PLEASE READ THIS ENTIRE MANUAL BEFORE INSTALLATION AND USE OF THIS PELLET FUEL-BURNING ROOM HEATER. FAILURE TO FOLLOW THESE INSTRUCTIONS COULD RESULT IN PROPERTY DAMAGE, BODILY INJURY, OR EVEN DEATH.

FOR USE IN THE U.S. AND CANADA. SUITABLE FOR INSTALLATION IN MOBILE HOMES

IF THIS HARMAN STOVE IS NOT PROPERLY INSTALLED, A HOUSE FIRE MAY RESULT. FOR YOUR SAFETY, FOLLOW INSTALLATION DIRECTIONS.

CONTACT LOCAL BUILDING OR FIRE OFFICIALS ABOUT RESTRICTIONS AND INSTALLATION INSPECTION REQUIREMENTS IN YOUR AREA.

CONTACT YOUR LOCAL AUTHORITY (SUCH AS MUNICIPAL BUILDING DEPARTMENT, FIRE DEPARTMENT, FIRE PREVENTION BUREAU, ETC.) TO DETERMINE THE NEED FOR A PERMIT.

CETTE GUIDE D'UTILISATION EST DISPONIBLE EN FRANCAIS. CHEZ VOTRE CONCESSIONNAIRE DE HARMAN HOME HEATING.

SAVE THESE INSTRUCTIONS.

#3-90-09730

Introduction

The Advance Pellet Heater

This heating appliance does not just have automatic ignition, it has total automatic temperature control. The Advance uses a small room sensor rather than a wall thermostat for a more accurate temperature control.

The Advance's control panel is designed for easy and efficient operation. It has 2 automatic modes of operation and 2 manual modes of operation. The Advance's specially designed burn pot and the "Advance Igniter" Automatic Ignition System, allow the unit to burn a large variety of biomass fuels with varying ash content. The Advance feed system has a maximum feed rate of 6 lbs. per hour and a minimum (maintenance) feed rate of 1.0 lbs. per hour.

This 0 to 48,000 BTU pellet stove has an accordion style heat exchanger system that allows maximum surface area for the most efficient heat transfer in a smaller firebox.

The unit has an easy to clean combustion system with an ash pan that holds ash from 1 ton of burned premium pellets. This unit is equipped with several different safety devices which will be explained later in this manual.

Please copy your serial number from the label on your stove to the box below.

SERIAL NUMBER

Model: ADVANCE
Room Heater Pellet Fuel Burning
Also for use in Mobile Homes.
This pellet burning appliance has been tested and listed for use in Manufactured Homes in accordance with OAR 814-23-900 through 814-23-909

Serial No. / N° de série: **008**

Modèle: ADVANCE
Voyez le chauffage à granulés de bois

Tests réalisés par OMNI TEST LABOR...
Essai selon les normes ASTM...
Appareil de chauffage...
NORMES EUROPÉENNES
NF EN 14181
NF EN 14182
NF EN 14183
NF EN 14184
NF EN 14185
NF EN 14186
NF EN 14187
NF EN 14188
NF EN 14189
NF EN 14190
NF EN 14191
NF EN 14192
NF EN 14193
NF EN 14194
NF EN 14195
NF EN 14196
NF EN 14197
NF EN 14198
NF EN 14199
NF EN 14200

SAMPLE LABEL ONLY

Appliance Certification.

Model: Advance Pellet Stove

Tested & Listed by: Omni-Test Laboratories

Type: Pellet Burning Room Heater

Standard(s): ASTM E1509-04, ULC S627-00 and ULC C1482-M1990.

Report #: 135-S-19b-6.2

Note: This appliance is also approved for installation into a shop.

SAFETY NOTICE: When installing a solid-fuel burning appliance, the installation of smoke detectors and carbon monoxide (CO) detectors is highly recommended. Note that the paint curing process may take some time. It is good to open a few windows near the appliance during the first few hours of burning, to eliminate un-necessary activation of the smoke or CO detectors.



BUILT TO A STANDARD. NOT A PRICE

352 Mountain House Road
Halifax, PA 17032
www.harmanstoves.com

Table of Contents

Automatic Operation	4
Manual Operation	6
ESP Control	8
Assembly & Installation	9
Venting	13
Maintenance	21
Trouble-Shooting	28
Specifications	29
Wiring Diagram	31
Warranty	32
Parts List	34
Corn Instructions	40
Power Failures	41

Automatic Ignition/Operation

The Advance pellet stove is more than just automatic ignition, it is also automatic temperature control. The automatic system will allow the fire size to be adjusted to match the heating needs and even put the fire out if necessary. If heat is needed after the fire is out, the Advance will automatically re-ignite and adjust the fire size to match the heating need. The totally automatic room sensor mode is recommended because of its efficiency.

The unit can be switched between "AUTO" and "MANUAL" at any time during operation.

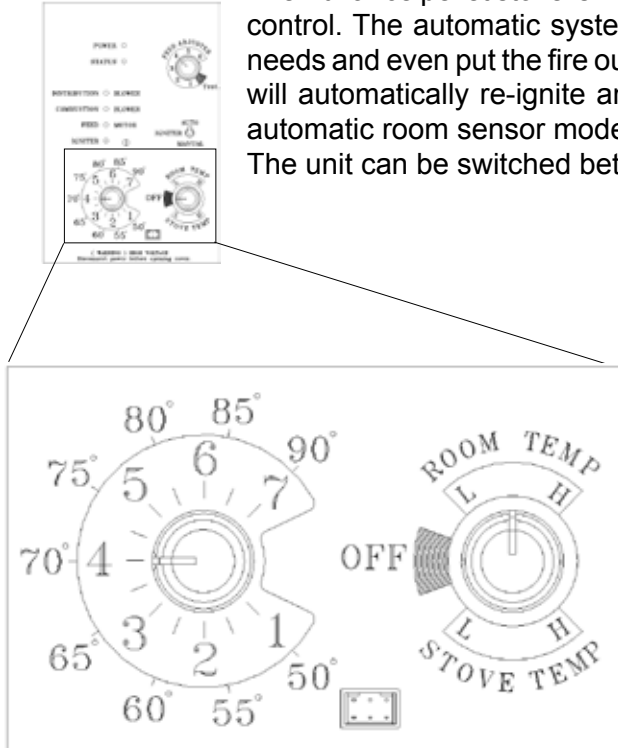

Room Temperature Mode: This setting will produce a room temperature of 70 degrees with the distribution blower at medium speed.

Stove Temperature Mode

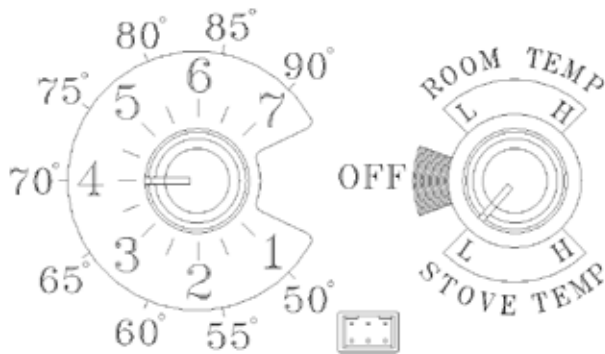

This setting will produce medium heat with the distribution blower on "low".

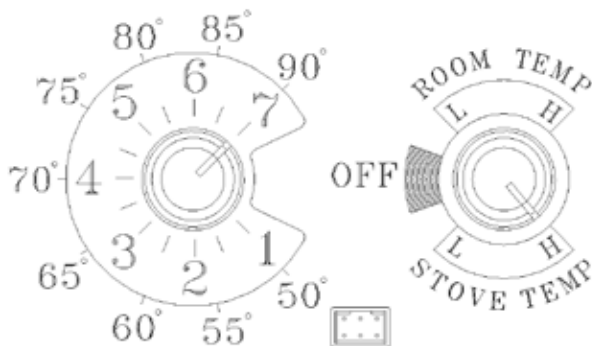

This setting will produce continuous maximum heat output with the distribution blower at full speed.

Igniter switch to "AUTO"

Room Temperature Mode

In "Room Temp Mode" heat output is controlled automatically by the Room Sensing Probe. When the Room Sensing Probe calls for heat, the stove will increase output. When the Room Sensing Probe is getting close to the set temperature, the stove will begin to level off output and keep the fire burning at just the right temperature to maintain that setting.

High output is determined by the feed rate setting. This setting, generally on #4, can be increased if higher burn rates are necessary. The unit's maximum burn rate should not create less than 1" of ash on the burn pot front edge. See Fig.2, Page 5. Overfeeding is not a safety concern, but fuel may be wasted if unburned pellets fall into the ash pan.

In "Room Temp Mode" a constant fuel consumption rate is sacrificed for exact room temperature. Therefore, as it gets colder more pellets will be burned automatically.

The distribution blower speed will vary according to the position of the mode selector pointer, and fire size.

Igniter switch to "AUTO"

Stove Temperature Mode

This allows for automatic ignition upon start-up only. The unit can then be set at any desired setting. The heat output and fuel consumption will remain constant regardless of room temperature. The unit's maximum feed rate should not create less than 1" of ash on the burn pot front edge. See Fig 2, Page 5.

The unit's low burn or maintenance setting is as low as it will go. It will not go out unless it runs out of fuel or is turned off.

Shut-down procedure

To kill the fire or stop burning the stove, turn the Mode Selector to "OFF". This will cause the fire to diminish and burn out. When the fire burns out and the stove cools down everything will stop.

If you pull the plug to shut down the stove, all motors will stop. This may cause incomplete combustion and smoke in the firebox. If the load door is opened the smoke may escape.

The best way to shut down the stove is simply let it run out of pellets, then the stove will shut down automatically.

Automatic Start Up

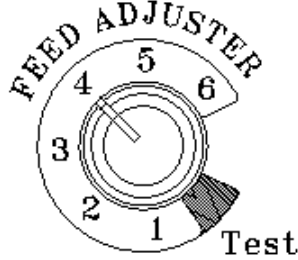

Fig. 1

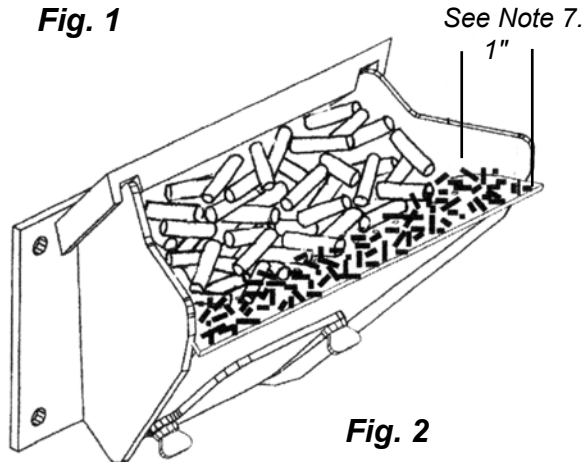

Fig. 2

1. Fines are small pieces of broken pellets (sawdust). Fines do not flow easily and often build up on the hopper funnel bottom angles. These fines can be pushed into the feeder opening and then fill the hopper with pellets. As the system works, they will be burned.
2. The "TEST" cycle will operate the feeder motor for exactly one minute. Turning to "TEST" again and again may purge too much fuel into the burn pot causing excessive smoke on start-up.
3. The firebox low pressure switch will not allow the auger motor or the igniter element to operate if the view door or the ash pan door are open.
4. Adjust Feed Rate. If this is your first fire or you are trying different pellets, set the feed adjuster to #4, Fig. 1. This is a conservative number and will probably need to be increased. After you know a feed rate setting that works well, use that setting. Remember, if your feed rate is too high you may waste fuel.
5. This is usually a weekly maintenance procedure. Cleaning the burn pot with the scraper with a small amount of new fuel in the bottom is not a problem. First, scrape the ashes on the front of the burn pot into the ash pan. Then scrape the holed surface downward into the burn pot. When the stove is ignited these scrapings will be pushed out by the feeder.
6. The ash pan can hold the ashes from approximately 1 ton of premium fuel. This means the ashes will only need to be emptied a few times a year.
7. Setting the feed adjuster # for maximum burn: With the unit burning in "AUTO", turn to "Stove Mode" and put the fan on "H". Set the Temperature Dial to #7. Allow the unit to burn for about 30 minutes and check ash on front of burn pot. Fig. 2. If the ash line is larger than 1", turn the feed adjuster from #4 to #5. Allow another 30 minutes of burn time and check again. If, at #6 setting, a 1" or less ash bed is not obtainable, it is not a problem. The 1" ash bed is only a maximum burn rate and at most normal settings the ash bed will be larger.

Starting First Fire

Igniter Switch to "AUTO" (up position)

Make sure the unit is plugged into a 120 VAC, 60 HZ electrical source. The power light should be the only light lit.

To avoid unwanted smoke, be sure there is no fuel or combustibles in the ash pan prior to lighting.

1. Turn Mode Selector to "OFF".
2. Fill hopper with pellets.¹
3. Clean burn pot with scraper, if necessary.⁵
4. If starting after an empty hopper, turn Feed Adjuster to "TEST" (for one 60 second cycle).² This will feed pellets into the auger tube and also allow you to check the motors for operation. **NOTE: The auger motor will not operate with the view door or ash pan door open.**³
5. Turn Feed Adjuster to #4.⁴
6. Flip the Igniter Switch up into the "AUTO" position.
7. Turn the Temperature Dial to desired room temperature.
8. Turn Mode Selector to Room Temperature or Stove Temperature.
9. Fill hopper with pellets and remove ashes as required.⁶

CAUTION

KEEP HOPPER LID, FIRE DOOR, AND ASH DRAWER PROPERLY CLOSED WHEN APPLIANCE IS IN OPERATION.

CAUTION

HOT WHILE IN OPERATION. KEEP CHILDREN, CLOTHING AND FURNITURE AWAY. CONTACT MAY CAUSE SKIN BURNS.

CAUTION

DO NOT USE CHEMICALS OR FLUIDS TO START THE FIRE. FOR EXAMPLE: NEVER USE GASOLINE, GASOLINE-TYPE LANTERN FUEL, KEROSENE, CHARCOAL LIGHTER FLUID, OR SIMILAR LIQUIDS TO START OR "FRESHEN UP" A FIRE IN THIS HEATER. KEEP ALL SUCH LIQUIDS WELL AWAY FROM THE HEATER WHILE IT IS IN USE.

Manual Ignition/Operation

The Advance Pellet Stove is capable of manual operation. This also allows the operator to manually control operation during an emergency (i.e. igniter failure.) The unit can be switched between "AUTO" and "MANUAL" at any time during operation.

NOTE: It is possible to start a fire in "Auto" and switch to "Manual" at any time. Once an ignition cycle begins, it will continue, regardless of mode.

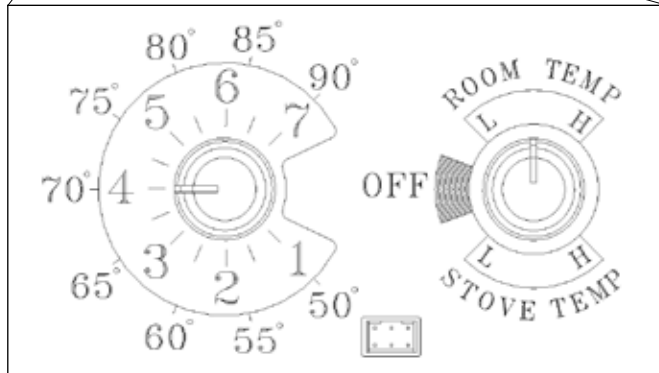
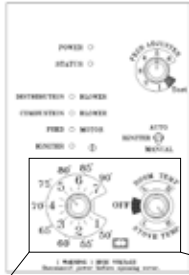

Room Temperature Mode: This setting will produce a room temperature of 70 degrees with the distribution blower at medium speed.

Igniter switch to "MANUAL"

Room Temperature Mode

The fire will have to be lit with starting gel and a match, or started automatically, see "Automatic Operation". Switch to "Manual" position after the ignition cycle begins.

The difference between "AUTO" Room Temperature Mode and "Manual" Room Temperature Mode is that the fire will not go out as the room temperature goes above the control board setting. The unit can only go to low burn and will remain there until it runs out of fuel or until more heat is needed and the feed rate increases. Feed rate adjustments and dial settings are the same as "AUTO" settings.

Manual Stove Temperature Mode

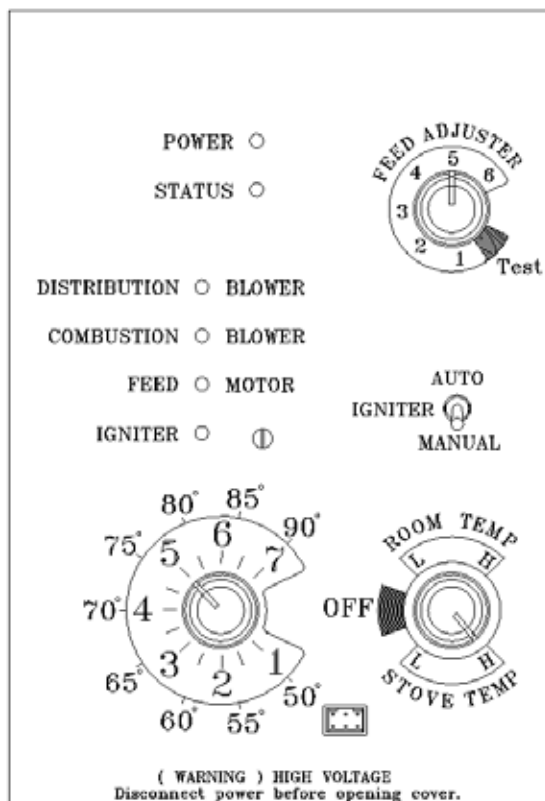

This setting will produce a large viewing fire without a distribution blower operating.

Igniter switch to "MANUAL"

Stove Temperature Mode

The advantage of this mode is to allow the operator to have a large viewing fire without blowing extra heat into the room.

During operation, with the temperature dial set at #3 or less, the distribution fan will not operate. A #3 on the temperature dial and a #5 on the feed adjuster is approximately 80% output. It is not necessary to operate the distribution blower below this point. Therefore, there can be a higher feed rate (a larger viewing fire) without an excess of hot air blowing into the room.

An example of when to use the Manual Stove Temperature Mode is if you want to watch a large fire and the room is already up to temperature. The Stove Temperature Mode allows you to have a larger fire and a lower sound level, without the distribution blower.

NOTE: During the use of this mode, if you keep increasing the temperature dial setting to increase the fire size, the distribution blower will automatically come on when the ESP Temperature reaches 350° F, or 81% output.

Manual Start Up

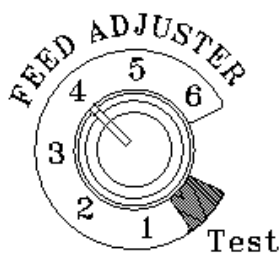

Fig. 3

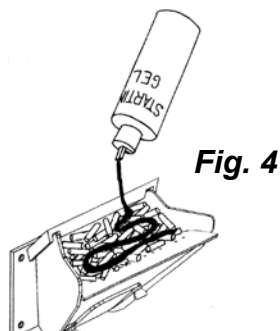

Fig. 4

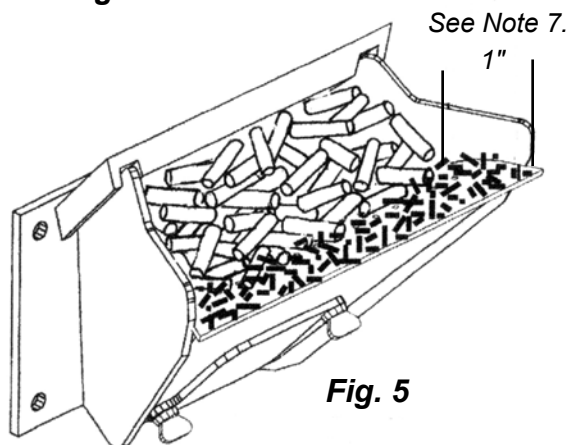

Fig. 5

1. Fines are small pieces of broken pellets (sawdust). Fines do not flow easily and often build up on the hopper funnel bottom angles. These fines can be pushed into the feeder opening and then fill the hopper with pellets. As the system works, they will be burned.
2. The "TEST" cycle will operate the feeder motor for exactly one minute. Turning to "TEST" again and again may purge too much fuel into the burn pot causing excessive smoke on start-up.
3. The firebox low pressure switch will not allow the auger motor or the igniter element to operate if the view door or the ash pan door are open.
4. Adjust Feed Rate. If this is your first fire or you are trying different pellets, set the feed adjuster to #4, Fig. 3. This is a conservative number and will probably need to be increased. After you know a feed rate setting that works well, use that setting. Remember, if your feed rate is too high you may waste fuel.
5. This is usually a weekly maintenance procedure. Cleaning the burn pot with the scraper with a small amount of new fuel in the bottom is not a problem. First, scrape the ashes on the front of the burn pot into the ash pan. Then scrape the holed surface downward into the burn pot. When the stove is ignited these scrapings will be pushed out by the feeder.
6. The ash pan can hold the ashes from approximately 1 ton of premium fuel. This means the ashes will only need to be emptied a few times a year.
7. Setting the feed adjuster # for maximum burn: With the unit burning in "AUTO", turn to "Stove Mode" and put the fan on "H". Set the Temperature Dial to #7. Allow the unit to burn for about 30 minutes and check ash on front of burn pot. Fig. 5. If the ash line is larger than 1", turn the feed adjuster from #4 to #5. Allow another 30 minutes of burn time and check again. If, at #6 setting, a 1" or less ash bed is not obtainable, it is not a problem. The 1" ash bed is only a maximum burn rate and at most normal settings the ash bed will be larger.

Starting First Fire

Igniter Switch to "MANUAL" (Down Position)

Make sure the unit is plugged into a 120 VAC, 60 HZ electrical source. The power light should be the only light lit.

To avoid unwanted smoke, be sure there is no fuel or combustibles in the ash pan prior to lighting.

1. Turn **FEED ADJUSTER** to desired feed rate. No. 4 is good for most pellets.⁴
 2. Turn the **MODE SELECTOR** to "OFF" and then to the desired mode. This will reset control and start the combustion motor.
 3. Turn the **TEMPERATURE DIAL** to the desired setting.
 4. Clean burn pot with scraper if necessary.⁵
 5. Fill burn pot with pellets, only level with front edge. (Do Not Over Fill).
 6. Apply starting gel on top of the pellets. Stir gel into pellets for fast lighting.
- SEE CAUTION BELOW.** The use of a starting gel that is commercially marketed for use with pellet stoves is permitted ONLY when performing a cold start. Also be sure to perform the above steps in sequence to ensure combustion blower operation before applying the starting gel. Follow the starter manufacturer's instructions for proper application.
7. **Light with a match, and close the door.** Operation will begin when the fire reaches the proper temperature.³
 8. **Fill hopper with pellets and remove ashes as required.**^{1, 6}

CAUTION

DO NOT USE CHEMICALS OR FLUIDS TO START THE FIRE. FOR EXAMPLE: NEVER USE GASOLINE, GASOLINE-TYPE LANTERN FUEL, KEROSENE, CHARCOAL LIGHTER FLUID, OR SIMILAR LIQUIDS TO START OR "FRESHEN UP" A FIRE IN THIS HEATER. KEEP ALL SUCH LIQUIDS WELL AWAY FROM THE HEATER WHILE IT IS IN USE.

ESP Control

Power Light

Indicates power to the control.

Status Light

Will be lit in either stove or room temp mode when pointer is not within off position band except after normal shut down. Blinks to indicate errors listed below.

Indicates power to distribution blower.

Indicates power to combustion blower.

Indicates power to the feed motor.

Indicates power to the igniter.

Temp dial

Allows you to adjust the room temperature in Room Temp Mode using the outer scale marked in degrees Fahrenheit. It also allows you to adjust the stove temperature while in Stove Temp Mode using the inner scale marked from 1 to 7.

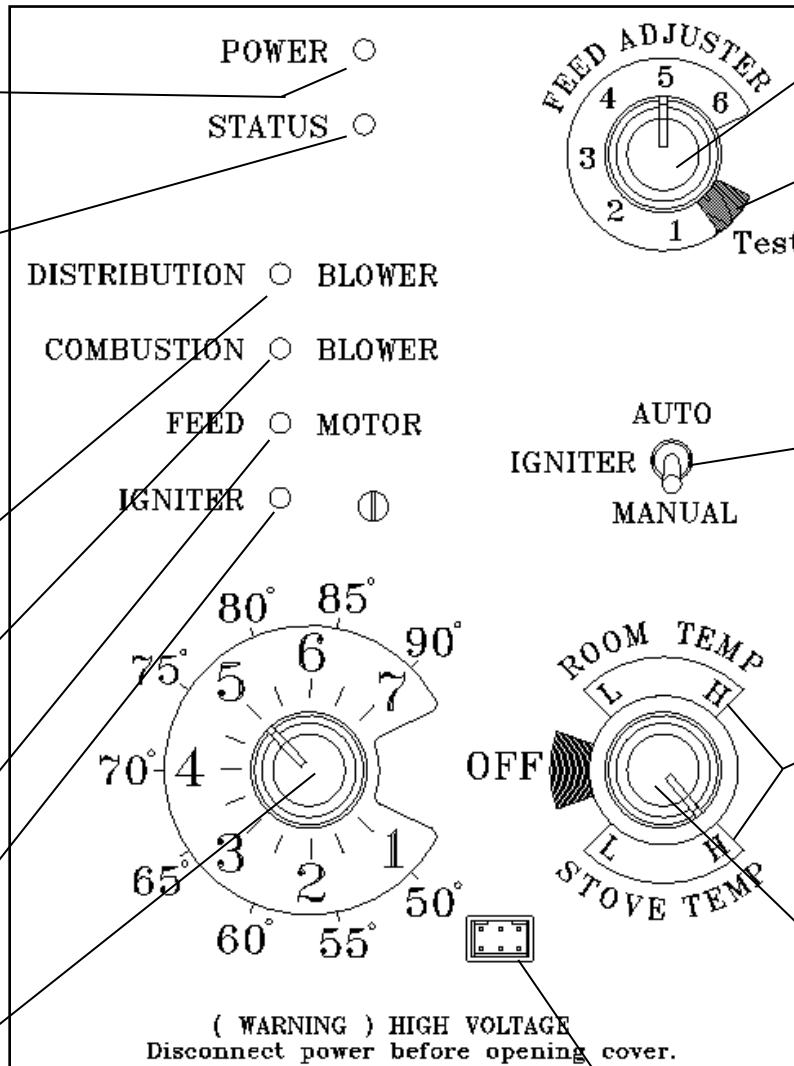

Feed adjuster

Sets the maximum feed rate

Test

Runs all motors at full speed for one minute to check operation. Afterward the combustion blower will stay on low to simulate a low burn rate.

Igniter switch

Set to appropriate Start-Up mode.

Distribution Blower speed adjustment range.

L = low

H = high

Variable speed anywhere between L and H; although as the stove temp. goes up, so does the low end of the scale.

Mode Selector

Allows you to choose between Room Temp Mode, Stove Temp Mode, or OFF. Also allows you to vary the distribution blower speed by turning the knob to the high or low side of each mode.

Dealer Diagnostic Port

For dealer maintenance only. Requires special DDM monitor supplied to Harman Dealers exclusively.

Status light error messages:

3 Blinks: Indicates a poor ESP connection or that the ESP (Exhaust Sensing Probe) has gone out of range too many times. If the stove seems to be operating normally, perform a manual reset*.

4 Blinks: Can occur only in Room Temp Mode and indicates Room Sensing Probe failed or not installed. If a Room Sensing Probe is then installed, the status light will automatically reset.

NOTE: Unit will not start in "AUTO" with this status error.

5 Blinks (In Igniter Auto. Mode Only): Indicates that the unit has failed to light after 4 consecutive igniter cycles, 32 minutes total. To reset - Turn Mode Selector to "OFF", then turn to either mode again.)

6 Blinks : Indicates that the control has calculated poor or incomplete combustion occurring for more than 50 minutes. See Troubleshooting section for more details. A six blink status may be set if the stove is allowed to run out of pellets. To reset, turn mode selector to "OFF" then back on to the desired mode. If the unit was not out of pellets, see Troubleshooting section for more details.

* **Manual reset-** disconnect power cord for a few seconds and reconnect. If error still occurs call your Dealer.

Installation

Consult with your local building code agency and insurance representative before you begin your installation to ensure compliance with local codes, including the need for permits and follow-up inspections.

Several issues must be addressed when selecting a suitable location for your Advance Pellet Stove. Observing required clearances to combustible materials, the proximity to a safe chimney or venting system, and the accessibility of electrical supply must all be considered. In addition, selecting a location that takes advantage of the building's natural air flow is also desirable to maximize the heating effectiveness of the heater. In many cases, this is a central location within the building.

Place the stove on a noncombustible floor or a floor protector that extends 6" (152mm) to the front, 6" (152mm) to the sides and 1" (25mm) to the rear of the stove. In the US, the front and side floor protection is measured from the door opening. In Canada, the measurements are from the appliance. (Fig. 8.) Floor protection must be placed under any horizontal venting. This protection must extend a minimum of 2" (51mm) beyond each side of the pipe.

Place the stove away from combustible walls at least as far as shown in figures 6, and 7. The clearance to a ceiling above the appliance is 24" (608mm).

Note that the clearances shown are minimum for safety, but do not leave much room for access when cleaning or servicing. Please take this into account when placing the stove.

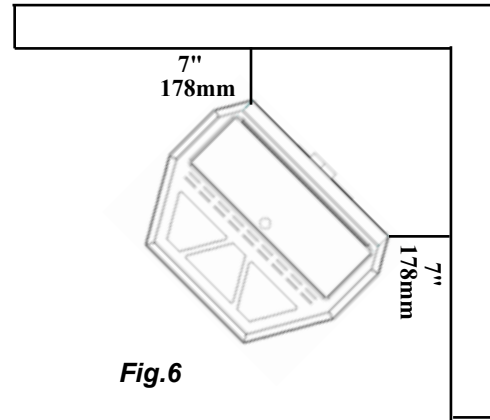

Fig.6

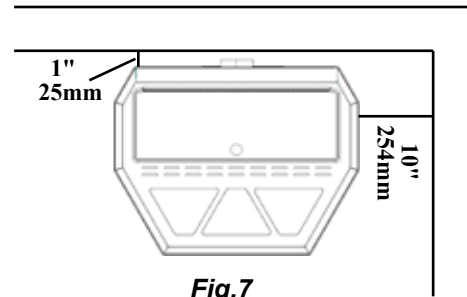

Fig.7

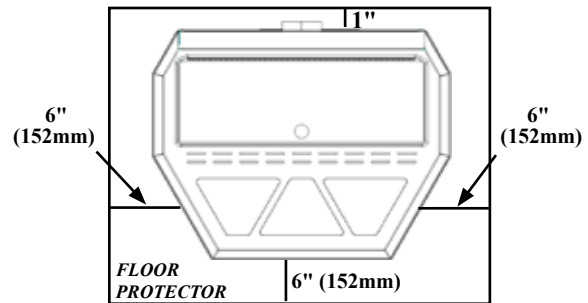

Fig.8

Mobile Home Installation

When installing this stove in a mobile home several requirements must be followed:

1. The unit must be bolted to the floor. This can be done with 1/4" lag screws through the 2 holes in the base plate shown in Fig. 11, Page 10.
2. The unit must also be connected to outside air. See page 14.
3. Floor protection and clearances must be followed as shown.
4. Unit must be grounded to the metal frame of the mobile home.

5. **WARNING - DO NOT INSTALL IN A SLEEPING ROOM.**

CAUTION: This appliance must be vented to the outside.

The factory-built chimney must conform to CAN/ULC-S629, Standard for 650°C Factory-Built Chimneys. Use the vent or chimney manufacturer's components to provide an effective vapor barrier where the vent penetrates to the exterior.

The top section(s) of chimney must be removable to a maximum height of 13' (3.9 M) to allow transport.

Installation and repair of this stove should be done by a qualified service person. The appliance should be inspected before use and at least annually by a qualified service person. Frequent cleaning will be required. It is imperative that control compartments, burners, and circulating air passageways of the stove be kept clean.

CAUTION
THE STRUCTURAL INTEGRITY OF THE
MANUFACTURED HOME FLOOR, WALL, AND
CEILING/ROOF MUST BE MAINTAINED.

CAUTION
HOT WHILE IN OPERATION.
KEEP CHILDREN, CLOTHING, AND
FURNITURE AWAY.
CONTACT MAY CAUSE SKIN BURNS.

Removing Side Doors for Installation

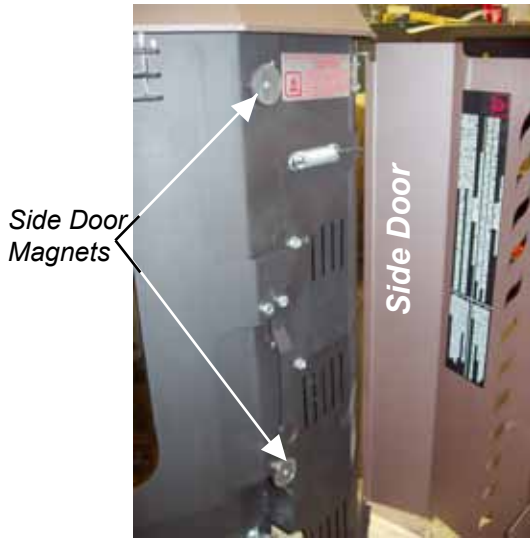
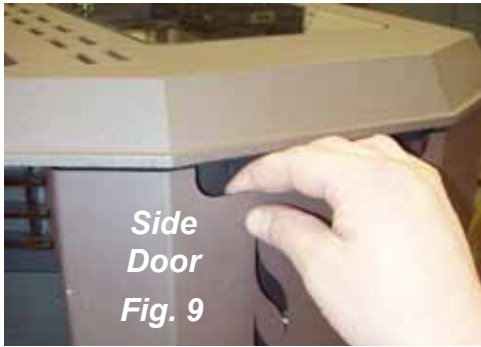

Fig.10



Fig.11



Fig.12

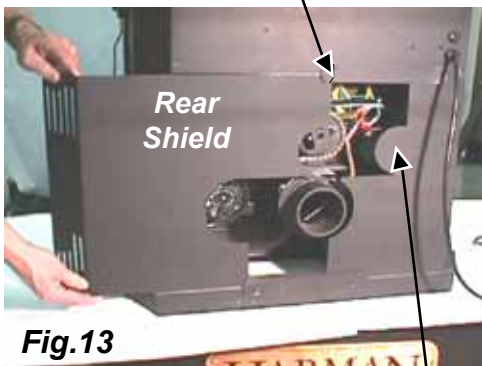

Fig.13

Removing Side Doors

Figure 9

Use hand hole to swing open side doors to at least 90°.

Figure 10

Remove side doors by lifting upward on the door until the bottom pin is out of its hole. Move the bottom of the door out and away from the pedestal base about 1/2". Allow the door to slide downward until the top door pin is out of its top hole.

NOTE: Always remove the side doors and rear shields to move the unit. This will keep them from getting damaged.

Removing the Rear Motor Shield Sheet Metal.

NOTE: Disconnect power to the unit before removing the motor shields. Danger of electrical shock. Hot and moving parts could cause injury.

Figure 11

There are (2) #10 hex head screws holding each rear shield. Using a 5/16" nut driver or socket, loosen the (2) screws about 4 or 5 turns.

Figure 12

Slide the rear shields straight outward until the ends come out of the rear retaining clips, as seen in Fig.13.

There are two bolts holding the stove to the pallet (see Fig. 11) Remove the bolts to move the stove.

Placing Rear Shields Back on Unit

1. When replacing the shields, always insert the top and bottom ends of the sheet metal into the retaining clips first.
2. Slide the shields straight inward until the (2) hex head screws are fully inserted into the stove slots.
3. Make sure the top edges of the shield are against the hopper bottom and tighten screws.

The rear shields are split around the flue tail pipe and outside air knockout. This allows removal and installation of the rear shields with the unit completely installed.

Low Draft Voltage Adjustment

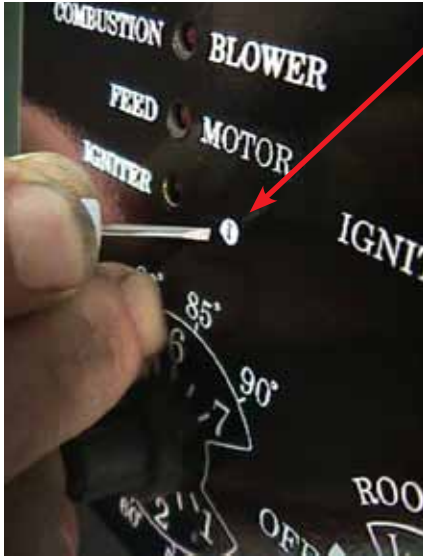

Fig.14

Combustion Motor Speed Control Low draft only set point.
The small straight screwdriver slot is plastic; therefore, the unit can be adjusted while in operation.



Fig.15: Draft Meter bolt hole location

These units are pre-tested at the factory with exactly 120 Volts A.C., 60 Hz. They are checked and adjusted for firebox tightness, gasket leakage, motor operation and igniter operation. The Advance is then factory set at a mid-point adjustment and in most cases will not need any adjustments. **NOTE: The factory low draft setting may not be correct for the unit's permanent installation conditions.**

The control board on the Advance is equipped with a low draft adjustment port, located on the control face just to the right of the igniter light. See Figure 14. This voltage adjustment is provided to allow the unit to be adjusted for the household voltage where the unit is going to be in permanent operation. NOTE: The line voltage varies from area to area and often home to home.

The low draft voltage should be adjusted to achieve the most efficient burn on low burn or "maintenance". This voltage adjustment allows the installer to change the low voltage set point approximately 15 volts. This adjustment should be done by the installer during set up because a draft meter reading is **required** to insure proper set up.

If the unit is not adjusted properly, it does not cause a safety concern. If the unit is adjusted too high, only efficiency is lost. If the unit is adjusted too low, the low draft pressure switch will not allow the feeder motor or the igniter to operate.

A simple draft test should be performed after completing the flue pipe installation. To record the results for future reference:

1. Plug unit into a 120 VAC, 60 HZ outlet.
2. Close the hopper lid, front view door, and the ash pan. Neither pellets nor a fire are required for this test.
3. With the mode selector in the "OFF" position, turn the feed adjuster to "TEST".
4. Record the high draft _____ in W.C. (Normal is -.50 to -.60) The control will be on the High Draft for a total of 2 minutes.
5. After 1 minute, the combustion motor will go down to low draft and the distribution blower will go on high. Allow approximately 15 seconds to pass for the combustion motor to slow before checking the low draft.
6. If the low draft is between .35 and .45, record the reading _____ in W.C. If the reading is higher, slowly turn the set screw counter-clockwise until the draft lowers. If the reading is lower, very slowly turn the set screw clockwise until the draft increases.

NOTE: In some cases, the draft may not go as low as .35 even with the set screw completely counter-clockwise.

Room Sensor and Air Grill Installation

Room Sensor Installation

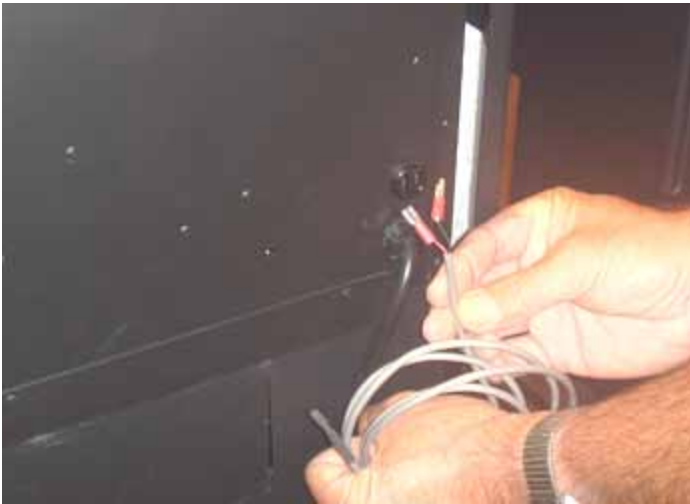

Fig. 16

The room sensor is a small temperature sensor on the end of a 60" gray or black wire. This sensor is installed much like a standard wall thermostat. Because it is so small, it can be hidden along the trim of a doorway or even up the leg of a coffee table. There is a remote room sensor port on the rear of the unit for easy external connection. Use standard 18-2 thermostat wire to extend the distance to the desired location (50' maximum). The room sensor should be installed in the location where you want to control the temperature.

NOTE: Distances of more than 25 feet from the unit or in another room are not recommended. It is recommended that the room sensor be installed, even if only installed on the rear of the unit as a return air sensor. The room sensor is essential for the Advance's excellent efficiency.

*Hopper Lid
Foam Gaskets*



Fig. 18

Do not allow pellets or sawdust to build up on the hopper lid gasket. Inspect the hopper lid gasket for damage. A good hopper lid seal is very important for proper operation.

Air Grill Installation



Fig. 17

Insert the two tail end hooks of the Air Grill Assembly up under the stove top edge. Insert inward until the two center hooks drop into the stove body slots in the front of the unit.

REMINDERS

Venting

Avoiding Smoke and Odors Negative Pressure, Shut-down, and Power Failure:

To reduce the probability of back-drafting or burn-back in the pellet burning appliance during power failure or shut-down conditions, the stove must be able to draft naturally without exhaust blower operation. Negative pressure in the house will resist this natural draft if not accounted for in the pellet appliance installation.

Heat rises in the house and leaks out at upper levels. This air must be replaced with cold air from outdoors, which flows into lower levels of the house. Vents and chimneys into basements and lower levels of the house can become the conduit for air supply, and reverse under these conditions.

Outside Air:

Harman Home Heating and Hearth & Home Technologies recommend attaching outside air in all installations, especially lower level and main floor locations.

Per national building codes, consideration must be given to combustion air supply to all combustion appliances. Failure to supply adequate combustion air for all appliance demands, may lead to back-drafting of those and other appliances.

When the appliance is side-wall vented: The air intake is best located on the same exterior wall as the exhaust vent outlet and located lower on the wall than the exhaust vent outlet.

When the appliance is roof vented: The air intake is best located on the exterior wall oriented towards the prevailing wind direction during the heating season.

The outside air connection will supply the demands of the pellet appliance, but consideration must be given to the total house demand. House demand may consume some air needed for the stove, especially during a power failure. It may be necessary to add additional ventilation to the space in which the pellet appliance is located. Consult with your local HVAC professional to determine the ventilation demands for your house.

NOTICE: In Canada, ULC-S627 requires that all outdoor-aired space heaters be secured to the structure.

Vent Configurations:

To reduce probability of reverse drafting during shut-down conditions, Hearth & Home Technologies strongly recommends:

- Installing the pellet vent with a minimum vertical run of five feet, preferably terminating above the roof line.
- Installing the outside air intake at least four feet below the vent termination.

To prevent soot damage to exterior walls of the house and to prevent re-entry of soot or ash into the house:

- Maintain specified clearances to windows, doors, and air inlets, including air conditioners.
- Vents should not be placed below ventilated soffits. Run the vent above the roof.
- Avoid venting into alcove locations.
- Vents should not terminate under overhangs, decks or onto covered porches.
- Maintain minimum clearance of 12 inches from the vent termination to the exterior wall. If you see deposits developing on the wall, you may need to extend this distance to accommodate your installation conditions.

Hearth & Home Technologies assumes no responsibility for, nor does the warranty extend to, smoke damage caused by reverse drafting of pellet appliances under shut-down or power failure conditions.

Venting

- ⊕ = Positive static pressure
- ⊖ = Negative static pressure

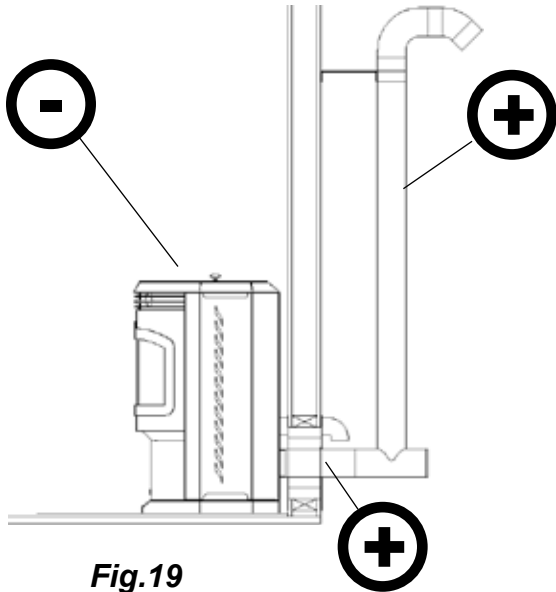
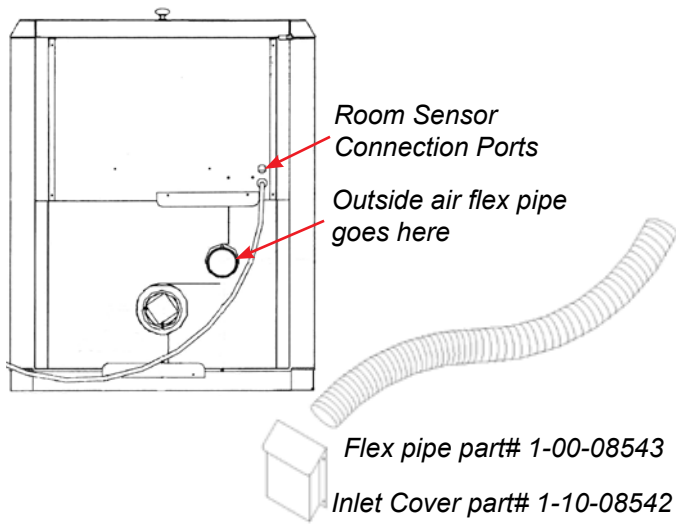
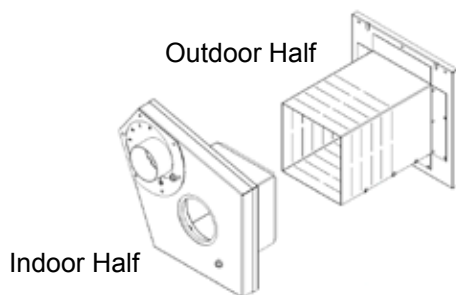

Fig.19



Direct Vent Wall Passthrough

The Harman Direct Vent Wall Passthrough (Part # 1-00-677077) makes installing your Harman Pellet Stove with outside air much easier. It is made to fit walls from 4 1/2" up to 10 1/8" thick with a square opening of 6" to 6 1/2".



USE 3 or 4 inch Pellet Vent pipe- (Type PL)

A combustion blower is used to extract the combustion gases from the firebox. This causes a negative pressure in the firebox and a positive pressure in the venting system as shown in fig. 19. The longer the vent pipe and more elbows used in the system, the greater the flow resistance. Because of these facts we recommend using as few elbows as possible and 15 feet or less of vent pipe. The maximum horizontal run should not exceed 48". If more than 15 feet of pipe is needed, the diameter should be increased from 3" to 4". **Be sure to use approved pellet vent pipe wall and ceiling pass-through fittings to go through combustibles.** Be sure to use a starting collar to attach the venting system to the stove. **All joints for connector pipe must be fastened with a minimum of three screws. Follow pellet vent manufacturer instructions for properly securing each pellet vent joint. The pellet starting collar must be secured to the unit's flue collar.**

Vent Pipe

Pellet venting pipe (also known as PL vent) is constructed of two layers with an air space between the layers. This air space acts as an insulator and reduces the outside surface temperature to allow a clearance to combustibles of only 3 inches or less. The sections of pipe lock together to form an air tight seal in most cases; however, in some cases a perfect seal is not achieved. For this reason and the fact that the Advance operates with a positive vent pressure, **we specify that the joints also be sealed with silicone.**

INSTALL VENT AT CLEARANCES SPECIFIED BY THE VENT MANUFACTURER.

CHIMNEY CONNECTOR MAY NOT PASS THRU AN ATTIC, ROOF SPACE, CLOSET, FLOOR, OR CEILING.

Outside Air

Outside air is necessary in mobile homes and where building codes require. The benefit of outside air is mainly noticed in small, very tight houses.

To install outside air use 2 3/8" I.D. flex pipe part number 1-00-08543. There is a break-away hole on the rear panel which must be removed before connecting the flex pipe. The pipe should be run outside and terminate to the side or below the vent pipe outlet so the flue outlet is more than 12" from the inlet cover. The maximum length run of this pipe is 15 feet. If a longer run is needed, the size must be increased to 3". Inlet cover part number 1-10-09542 should be used to keep birds, rodents, etc. out of pipe.

Venting

#1 Preferred method

This method provides excellent venting for normal operation and allows the stove to be installed closest to the wall. One inch from the wall is safe; however, two or three inches allows better access to remove the rear panel. The vertical portion of the vent should be three to five feet high. This vertical section will provide natural draft in the event of a power failure.

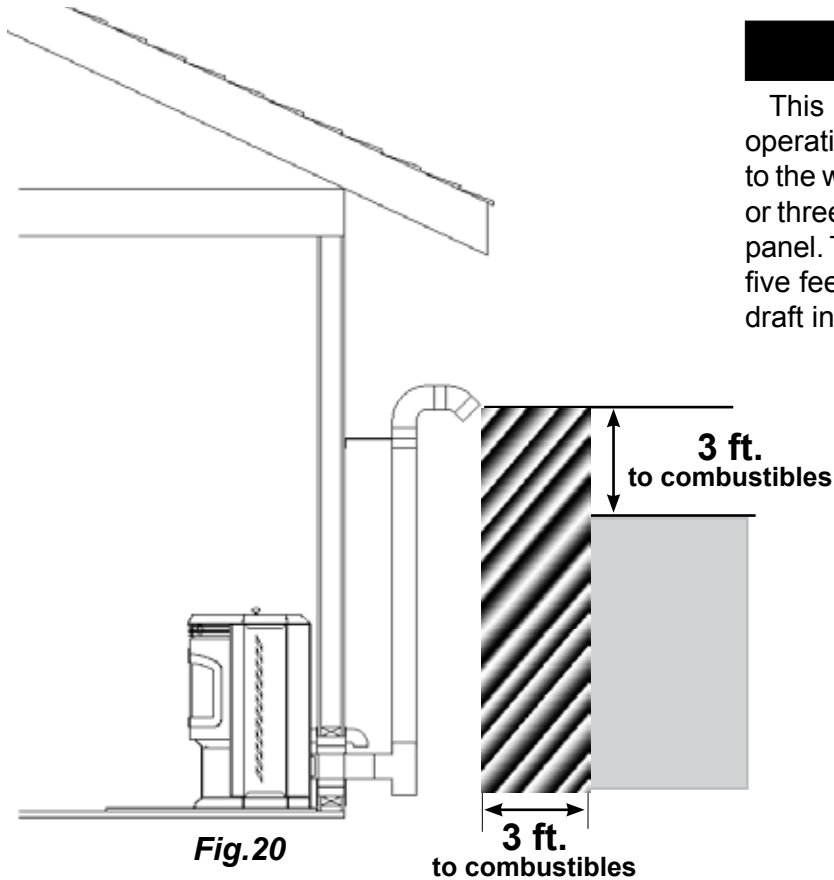

#2 Preferred method

This method also provides excellent venting for normal operation but requires the stove to be installed farther from the wall. The vertical portion of the vent should be three to five feet high and at least three inches from a combustible wall. This vertical section will provide natural draft in the event of a power failure.

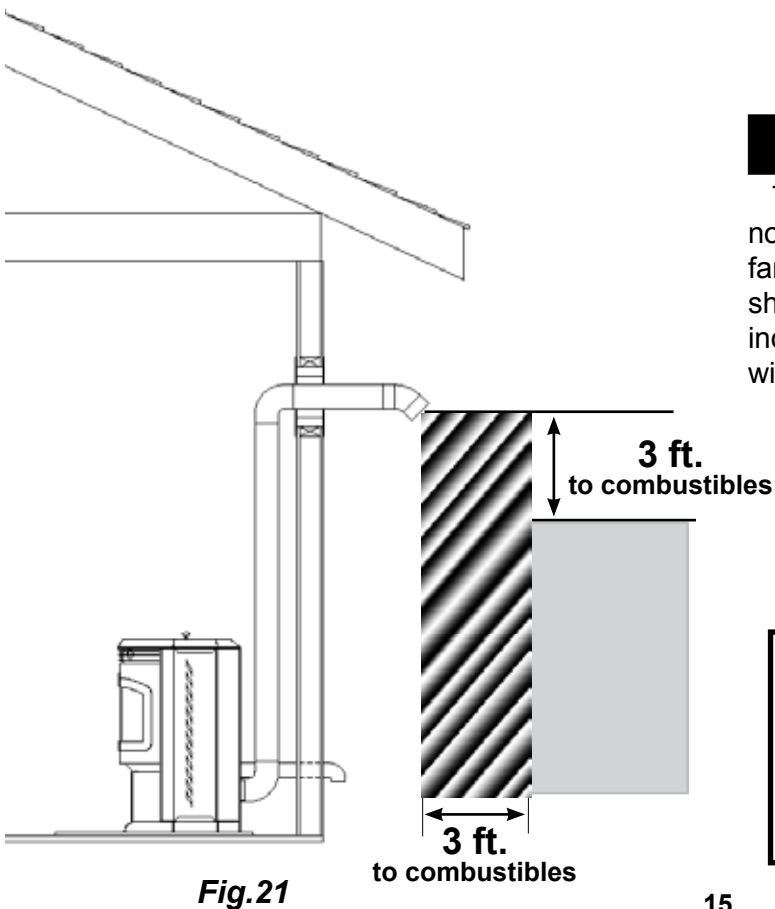

CAUTION
KEEP COMBUSTIBLES (SUCH AS GRASS, LEAVES, ETC.) AT LEAST 3 FEET AWAY FROM THE FLUE OUTLET ON THE OUTSIDE OF THE BUILDING.

Venting

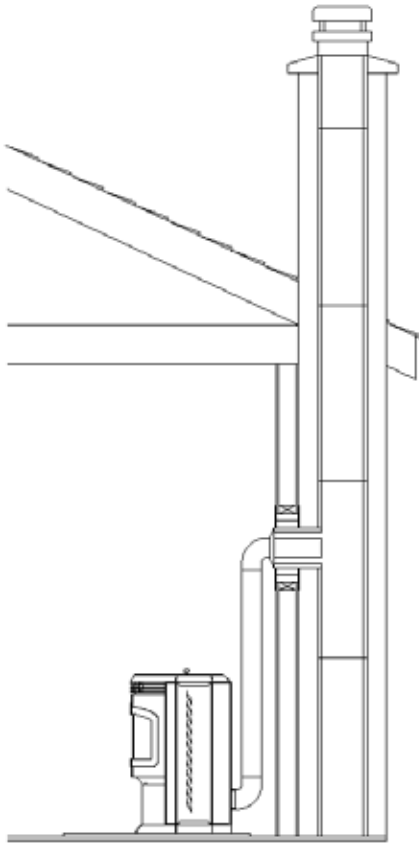

Fig.22

#3 Installing into an existing chimney

This method can be used for normal operation. This method also provides natural draft in the event of a power failure. If the chimney condition is questionable you may want to install a liner as in method #6.

THE CHIMNEY MUST BE OF A TYPE SUITABLE FOR SOLID-FUEL BURNING.

**WARNING!
THE CHIMNEY AND CONNECTOR MUST BE MAINTAINED IN GOOD CONDITION AND KEPT CLEAN.**

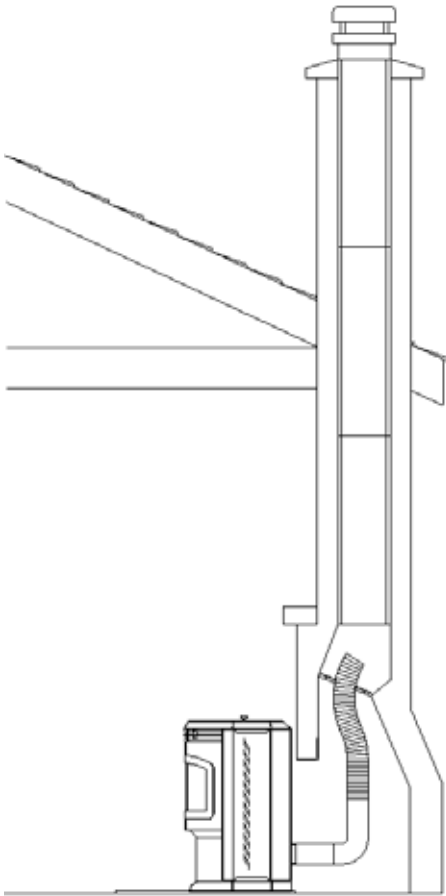

Fig.23

#4 Installing into an existing fireplace chimney

This method can be used for normal operation. This method also provides natural draft in the event of a power failure.

The damper area must be sealed with a steel plate (not supplied). Kaowool, mineral wool or an equivalent non-combustible insulation is recommended to be installed on top of the sealing plate, to reduce the possibility of condensation. A cap should be installed on the chimney to keep out rain. If the chimney condition is questionable you may want to install a liner all the way to the top as in Method #5.

Venting

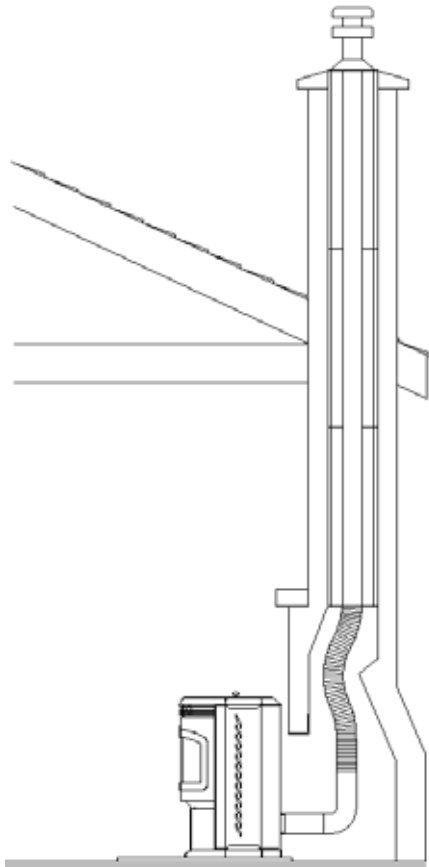

Fig.24

#5 Installing into an existing fireplace chimney

This method provides excellent venting for normal operation. This method also provides natural draft in the event of a power failure.

In Canada and some places in the US it is required that the vent pipe extend all the way to the top of the chimney.

In this method a cap should also be installed on the chimney to keep out rain. Be sure to use approved pellet vent pipe fittings. Seal pipe joints with silicone in addition to the sealing system used by the manufacturer. Pipe size should be increased to 4" using this method.

THE CHIMNEY MUST BE OF A TYPE SUITABLE FOR SOLID-FUEL BURNING.

WARNING!
THE CHIMNEY AND CONNECTOR MUST BE MAINTAINED IN GOOD CONDITION AND KEPT CLEAN.

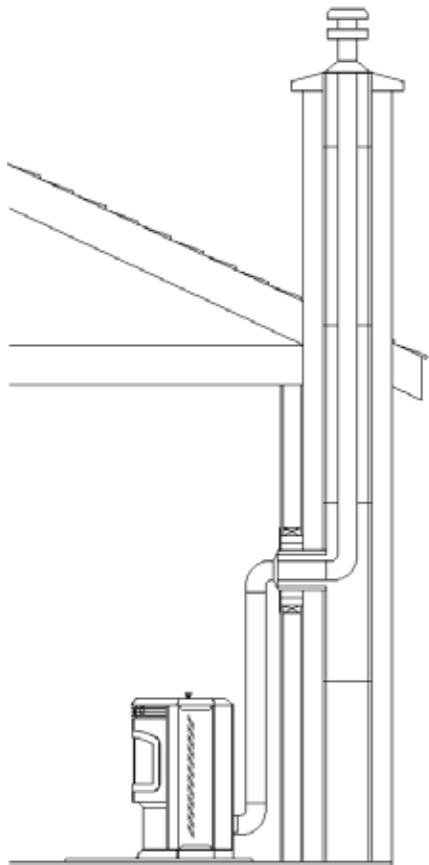

Fig.25

#6 Installing into an existing chimney

This method provides excellent venting for normal operation. This method also provides natural draft in the event of a power failure.

In Canada and some places in the US it is required that the vent pipe extend all the way to the top of the chimney. The pipe or liner inside the chimney should be 4" diameter.

In this method a cap should also be installed on the chimney to keep out rain.

Venting

#7 Installing through the ceiling vent

Through the ceiling vent, follow PL vent manufacturer's recommendations when using wall and ceiling pass through.

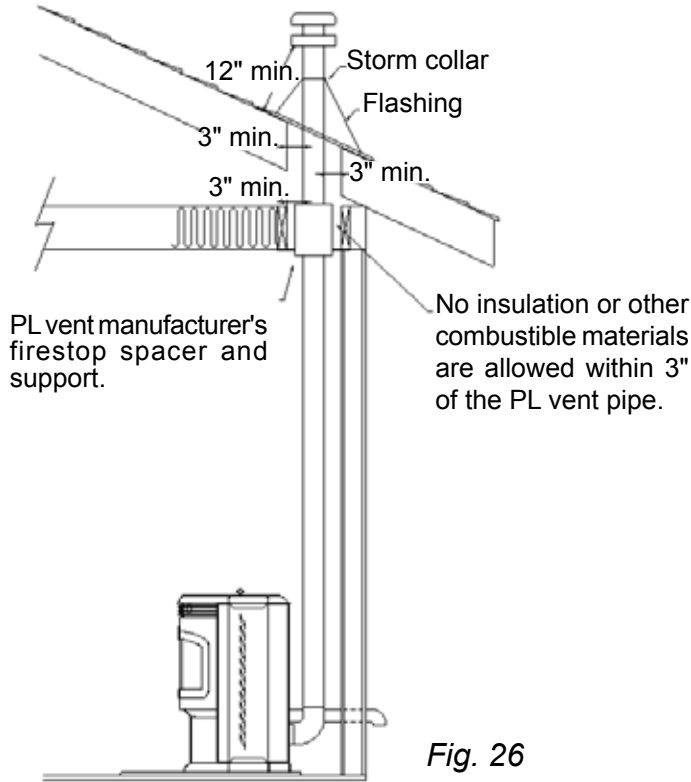

Minimum flue vent configuration

It is recommended that outside air be installed with this venting configuration.

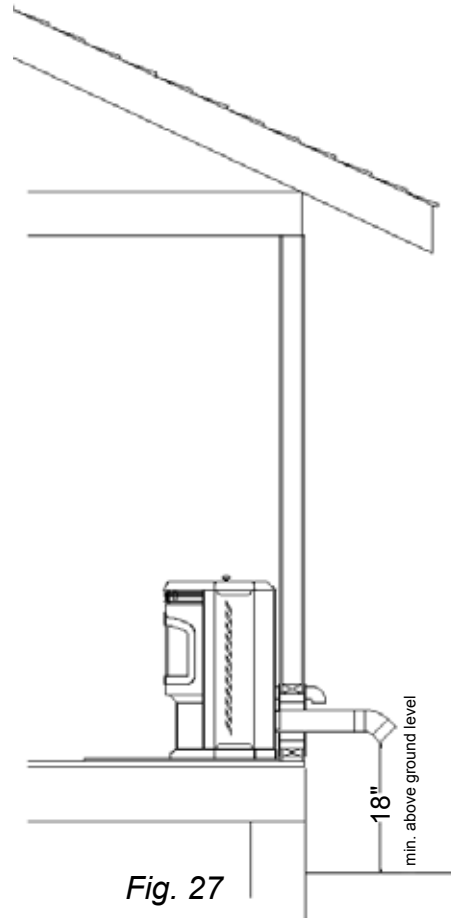

CAUTION
Keep any materials that may be affected by the elevated exhaust temperatures at least 3 feet away from the flue termination.

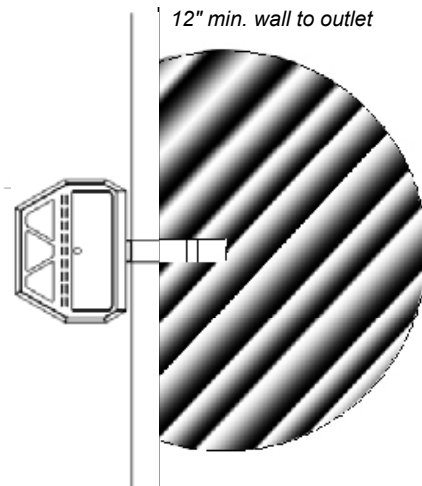

Fig. 28

Venting

Requirements for Terminating the Venting

WARNING: Venting terminals must not be recessed into a wall or siding.

NOTE: Only PL vent pipe wall pass-throughs and fire stops should be used when venting through combustible materials.

NOTE: Always take into consideration the effect the prevailing wind direction or other wind currents will cause with flyash and /or smoke when placing the termination.

In addition, the following must be observed:

A. The clearance above grade must be a minimum of 18".¹

B. The clearance to a window or door that may be opened must be a minimum of 48" to the side, 48" below the window/door, and 12" above the window/door.¹

(with outside air installed, 18" below or beside, and 9" above.)

C. A 12" clearance to a permanently closed window is recommended to prevent condensation on the window.

D. The vertical clearance to a ventilated soffit located above the terminal within a horizontal distance of 2 feet (60 cm) from the center-line of the terminal must be a minimum of 18".

E. The clearance to an unventilated soffit must be a minimum of 12".

F. The clearance to an outside corner is 11" from center of pipe.

G. The clearance to an inside corner is 12".

H. A vent must not be installed within 3 feet (90 cm)

above a gas meter/regulator assembly when measured from the horizontal center-line of the regulator.¹

I. The clearance to service regulator vent outlet must be a minimum of 6 feet.¹

J. The clearance to a non-mechanical air supply inlet to the building or the combustion air inlet to any other appliance must be a minimum of 48".¹

K. The clearance to a mechanical air supply inlet must be a minimum of 10 feet.¹

(with outside air installed, 6 feet)

L. The clearance above a paved sidewalk or a paved driveway located on public property must be a minimum of 7 feet.^{1,2}

M. The clearance under a veranda, porch, deck or balcony must be a minimum of 12 inches.^{1,3} **(See B.)**

NOTE: The clearance to vegetation and other exterior combustibles such as mulch is 36" as measured from the center of the outlet or cap. This 36" radius continues to grade or a minimum of 7 feet below the outlet.

¹Certain Canadian and or Local codes or regulations may require different clearances.

²A vent shall not terminate directly above a side-walk or paved driveway which is located between two single family dwellings and serves both dwellings.

³Only permitted if veranda, porch, deck, or balcony is fully open on a minimum of 2 sides beneath the floor.

NOTE: Where passage through a wall, or partition of combustible construction is desired, the installation shall conform to CAN/CSA-B365. (if in Canada)

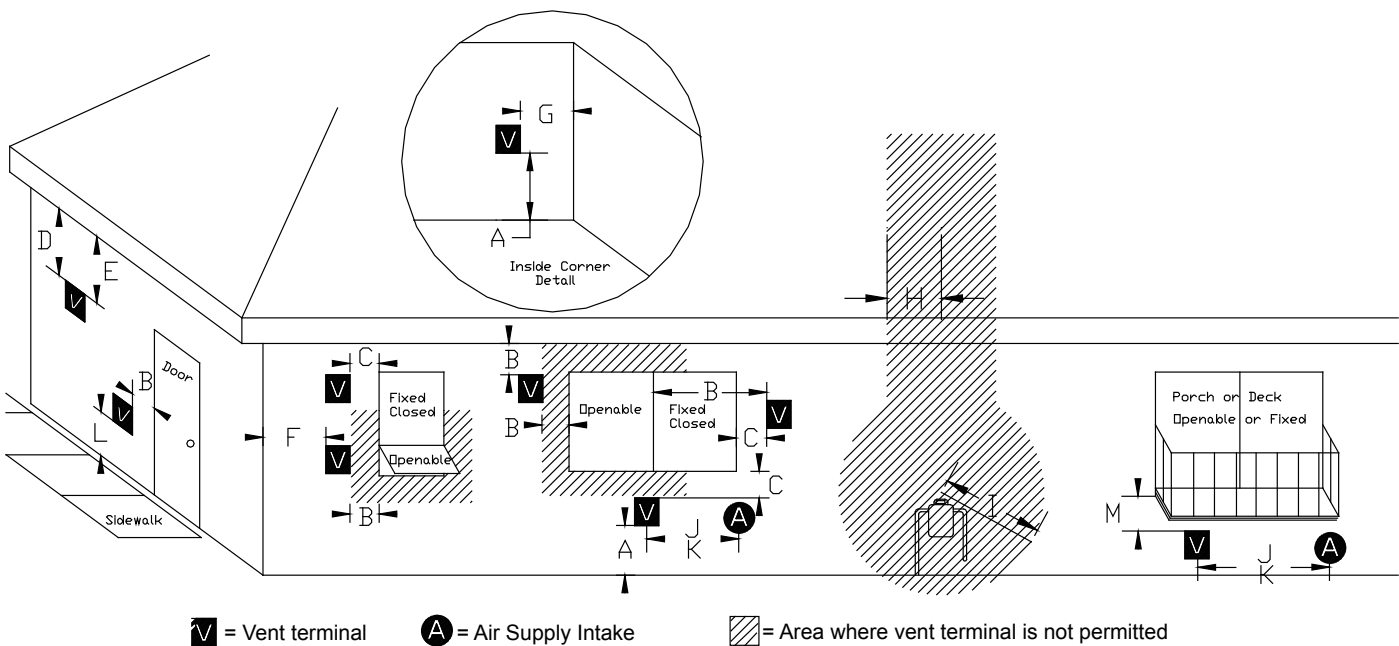

Safety Information

DO NOT INSTALL A FLUE DAMPER IN THE EXHAUST VENTING SYSTEM OF THIS UNIT.

DO NOT CONNECT THIS UNIT TO A CHIMNEY FLUE SERVING ANOTHER APPLIANCE.

INSTALL VENT AT CLEARANCES SPECIFIED BY THE MANUFACTURER

Mobile home installation should be done in accordance with the Manufactured Home and Safety Standard (HUD), CFR 3280, Part 24.

DO NOT USE MAKESHIFT COMPONENTS OR OTHER COMPROMISES WHEN INSTALLING THIS APPLIANCE.

DO NOT CONNECT THIS APPLIANCE TO ANY AIR DISTRIBUTION DUCT OR SYSTEM.

WARNING

MOBILE HOME REGULATIONS DO NOT ALLOW INSTALLATION IN A ROOM DESIGNATED FOR SLEEPING.

CAUTION

THE STRUCTURAL INTEGRITY OF THE MOBILE HOME FLOOR, WALL, AND CEILING/ROOF MUST BE MAINTAINED.

CAUTION

KEEP COMBUSTIBLES AWAY FROM FLUE OUTLET.

CAUTION

DO NOT BURN GARBAGE OR FLAMMABLE FLUIDS SUCH AS GASOLINE, NAPTHA OR ENGINE OIL.

WARNING

Keep combustible materials such as grass, leaves, etc. at least 3 feet away from the point directly under the vent termination.

Maintenance - Emptying Ashes



Ash Pan Removal and Reattachment

CAUTION: Surfaces are hot while in operation, Wear gloves to protect from burns.

Figure 29

Open side doors.

Figure 30

Release spring latches on the right and left side of the ash pan.



Figure 31

Slide ash pan forward enough to lift with center handle. Empty ashes and reinstall ash pan.

Disposal of Ashes- Ashes should be placed in a steel container with a tight fitting lid. The closed container of ashes should be moved outdoors immediately and placed on a noncombustible floor or on the ground, well away from all combustible materials, pending final disposal. If ashes are disposed of by burial in soil or otherwise locally dispersed, they should be retained in the closed container until all cinders have thoroughly cooled. Other waste shall not be placed in this container.

Figure 32

Inspect the gasket rope for damage. Replace if necessary.

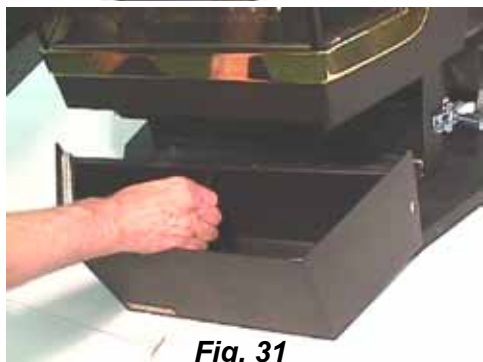

Figure 33

Insert spring latch front hooks into the ash pan side slots. Push both latches to the rear at the same time to latch.

Soot and Fly Ash

Formation and Need For Removal -The products of combustion will contain small particles of fly ash. The fly ash will collect in the exhaust venting system and restrict the flow of the flue gases. Incomplete combustion, such as occurs during startup, shutdown, or incorrect operation of the room heater, will lead to some soot formation which will collect in the exhaust venting system. The exhaust venting system should be inspected at least once every year to determine if cleaning is necessary.

When removing the ash pan to empty ashes, you will note a build up of ash fines behind the ash pan. This space behind the ash pan was designed to allow the fines to fall out of the vertical heat exchangers and collect where they are easily cleaned out, rather than going into the flue pipe where it would be difficult to clean. These fines should not be allowed to build up. They may not allow the ash pan to be seated into its gasket properly.

NOTE: If an extreme amount of force is required to snap the latch on one or both sides of the ash pan, the area behind the ash pan should be checked for ash build up.



Maintenance - Cleaning Glass on View Door

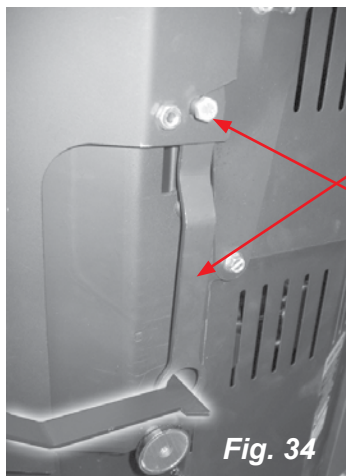

WARNING
Door latch may
be hot!

Receiving Bolt

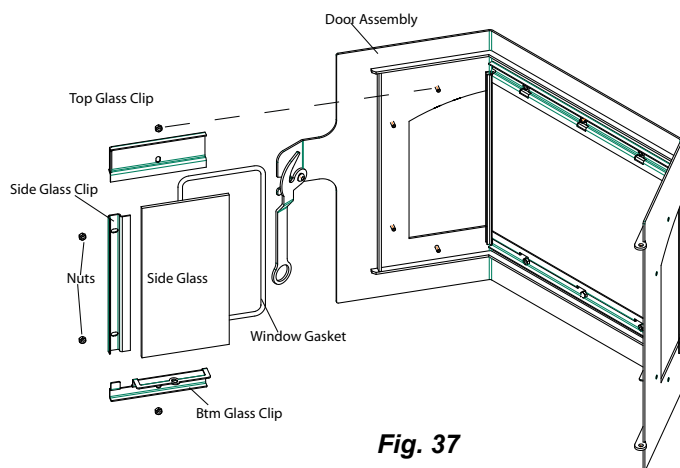
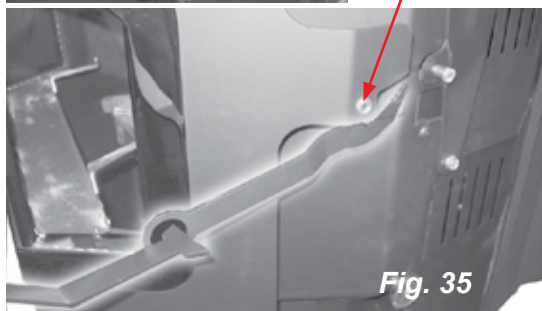

Opening:

The view door must be opened for cleaning of the glass and scraping of the burn pot. This should be done with the unit off and cool, in most cases. Although the glass can be cleaned and burn pot scraped while the unit is at low burn.

1. Using scraper as shown in Fig. 34 and 35, lift the door latch forward and up.
2. Swing the door open to the left, stopping the swing when resistance is felt. Forcing the door open further than it is designed, may cause damage to the door or it's hinges.

CAUTION

Do not put excessive downward pressure on the latch end of the door while in the open position.

If the door is going to be opened for an extended period of time, it is suggested that it be removed (see Fig. 36) and set safely aside.

3. Inspect the door gasket and glass gaskets for worn or missing pieces. Replace if necessary. (Fig. 37)

Closing:

When closing the door, always hold the door latch all the way up until it has caught the receiving bolt. Then push the latch downward and back until the door is fully seated. See Fig. 35.

Removing View Door:

To remove the view door from the stove, hold the door by the bottom and lift upward, off of the hinge pins. See Fig. 36.

The glass in your Harman stove is a special ceramic glass.

DO NOT abuse the glass by striking or slamming shut.

Never burn the appliance if the door glass is cracked or broken.

Replace only with Harman supplied 5mm ceramic glass.

WARNING - Do NOT Use Substitute Materials.

Clean the glass with a soft cloth and mild glass cleaner. Do not clean the glass when hot, and avoid the use of abrasive cleaners.

Glass replacement:

Carefully remove all remaining glass and gasket materials prior to replacing the glass.

Lay the door face down on a flat surface. Remove the glass retainers and screws. Apply the gasket material to the face of the new glass. Lay the glass into the door. Lay the glass retainers into position and install the nuts. Tighten each nut evenly, to avoid making any stress points.

Maintenance - Burn Pot

Burn Pot Cleaning and Maintenance

1. Scrape the top holed surface and sides of the burn pot. (Fig. 38) It is not necessary to completely remove all material from the burn pot. The excess will be pushed out during the next use.
2. Loosen the (2) wing thumb screws on the lower front angle of the burn pot. (Fig. 38)
3. Lift off the clean-out cover (Fig.39) to open the bottom clean-out chamber. (Fig.40)

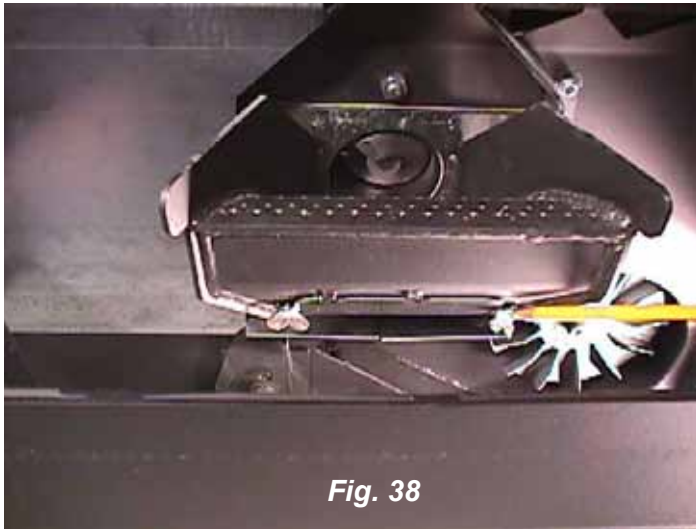

Fig. 38

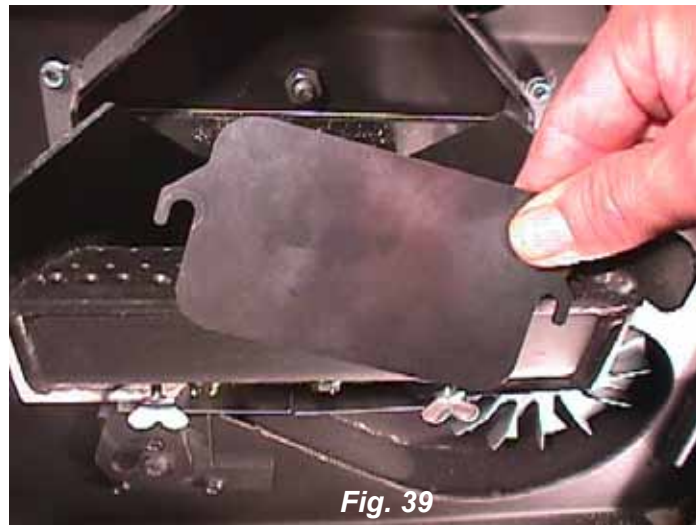
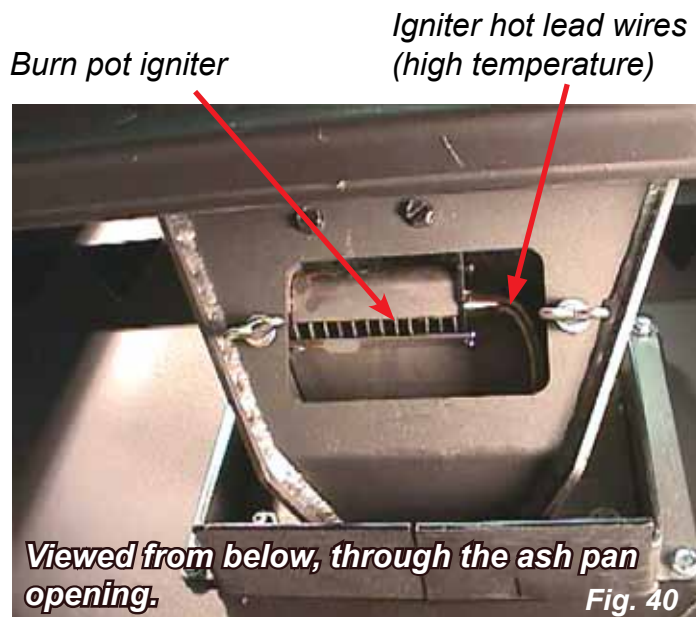

Fig. 39



DANGER

Disconnect the power to the unit before removing cover.

4. Clean ash buildup from inside the chamber while cover is off. Use the scraper to tap on the top front edge of the burn pot. This will help knock pieces of ash, loosened by the scraping process, down through the holes. It also helps knock scale off of the igniter element.

Figure 40

The igniter is made to be removable for service by insulated male/female wire connectors. These connections between the hot leads (the wires inside the burn pot) and the cold leads (the wires from the control board) are always pulled to the rear of the feeder body. **(Not coiled inside the burn pot.)**

It is very important that these connections are to the inside rear of the feeder body. Also, the extra wire of the igniter wire service loop must be pulled out through the rear of the feeder and tied up so that it will not be damaged by any moving parts. See page 27.

Warning

Use caution when cleaning burn pot clean-out chamber. Do not damage the high temperature igniter wires.

DANGER

Disconnect the power to the unit before removing cover.

Note: The hot lead/cold lead connection must always be pulled to the rear of the feeder body before operation.

Maintenance - Flame Guide and Brick Panel

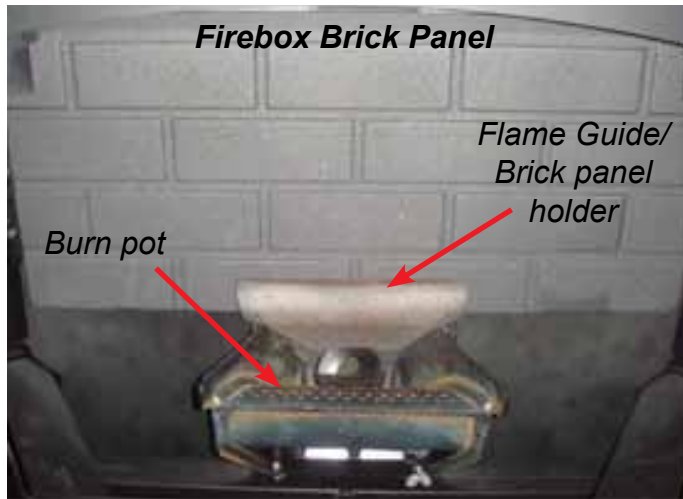

Flame Guide and Brick Panel Removal for Cleaning

Figure 41

Slide brick panel straight upward with both hands.

Figure 42

While holding the brick panel up with one hand, remove the flame guide from the top of the burn pot.

Figure 43 & 44

Slide the brick panel into the left corner of the firebox with the panel resting on the top edges of the burn pot. Rotate the right side of the brick panel through the door opening.

Reverse this operation to reinstall the brick panel after cleaning.



Fig. 41



Fig. 43



Fig. 42



Fig. 44

Maintenance - Combustion Intake Cover

Cover Retainer Handle

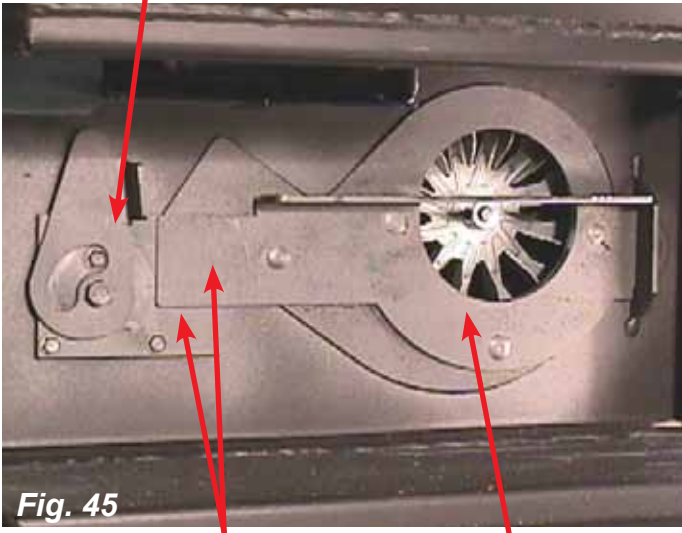

Fig. 45
These surfaces must be even to close retainer handle.

Combustion Intake Cover

Cleaning and Maintenance for the Combustion Intake Cover

You will need to remove the combustion intake cover, behind the ash pan, to clean the fan blades and rear flue tube.

Figure 45

Rotate the retainer cover handle counter-clockwise upward as far as it will go (approximately 90°).

Figure 46

Hold the intake cover handle and pull until the side of the cover at the retainer handle end comes away from the stove body, approximately 15-20°, slide the right side tab out of the retaining slot.

Figure 47

Clean and inspect the fully exposed combustion fan blade and flue tube.

Reinstall the combustion intake cover by first sliding the right side tab into the retainer slot seen in Figure 47. Rotate the cover inward until the cover fits into its hole. Make sure the two faces (Fig.46) of the cover and retainer spacer are even and rotate the retainer handle clockwise until it stops.

CAUTION

Excessive cleaning force could bend the small stainless steel ESP, causing damage.

Creosote: Formation and The Need for Removal:

Whenever wood is burned, there is a potential for creosote formation. The venting system should be inspected periodically during the heating season to determine if a creosote buildup has occurred. If a significant layer of creosote has accumulated (3 mm or more), it should be removed to reduce the risk of a chimney or venting system fire.

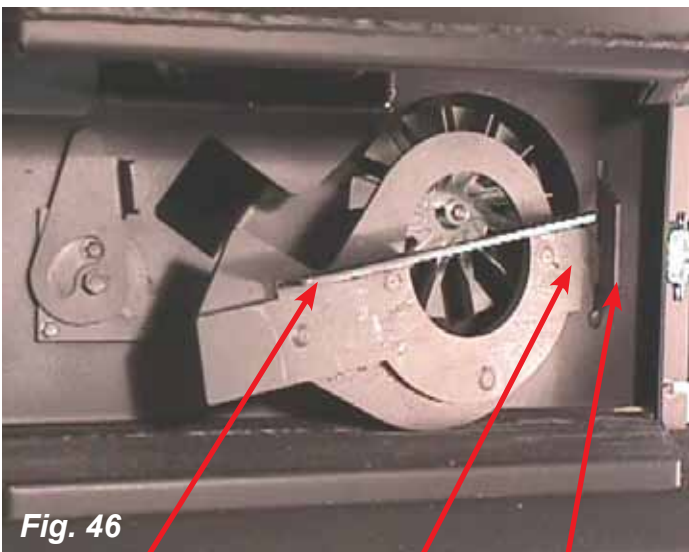

Fig. 46

Intake Cover Handle

Right Side Tab

Right Side Retaining Slot

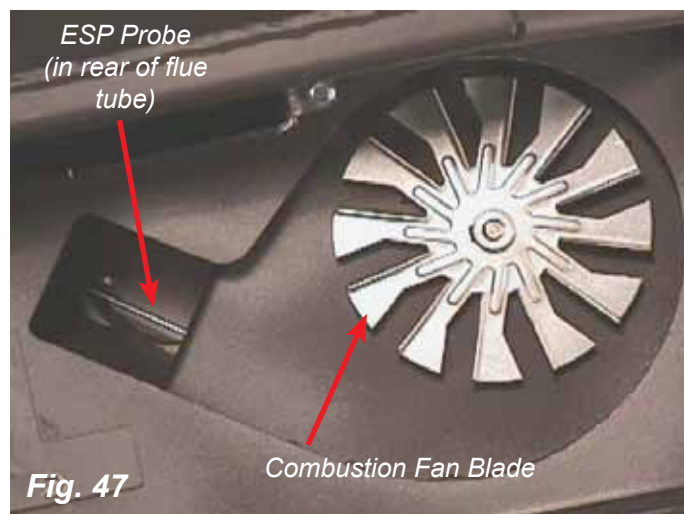
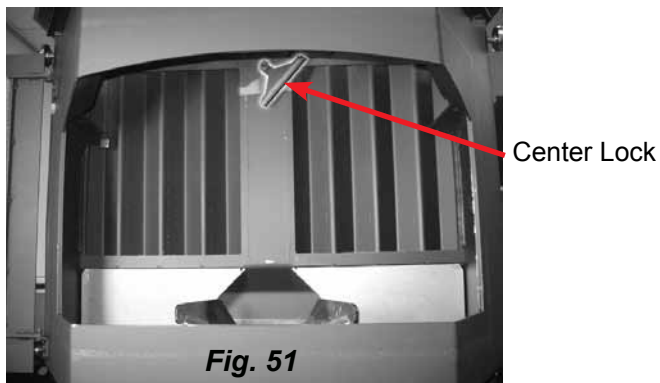
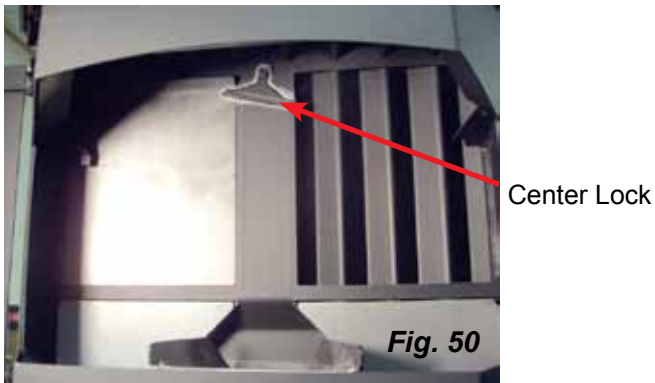

Fig. 47

Combustion Fan Blade

Maintenance - Heat Exchanger



Cleaning the Heat Exchanger System

1. Remove brick panel and flame guide. (See Pg 24.)
2. Remove the ash pan. See Page 21.
3. Remove flue baffles located on each side of the burnpot, see Fig. 48 & 49. The baffle is held in place by inserting the tab into the slot (located toward the outside of the firebox) and resting it on the hook tab located beside the burnpot.
4. Pull the pointed end of the baffle slightly front with one hand while pushing up from below with the other hand. See Fig. 49.
5. With the baffle released from the tabs, rotate the pointed end toward the door opening. Lift baffle up and out.
The right and left baffle are interchangeable.
6. Now remove the heat exchanger baffle plates. See Fig. 50 & 51. To remove the left plate, slide the center lock to the right. To remove the right plate, slide the center lock to the left. (The right and left plates are interchangeable.)
This will allow access to all of the rear vertical heat exchanger surfaces.
7. With all four baffle plates removed, cleaning can be performed with the arrow end of the scraper. See Fig. 52.
8. Scrape all of the heat exchanger surfaces. (Be sure to clean any internal ledges where fly ash could have collected.)

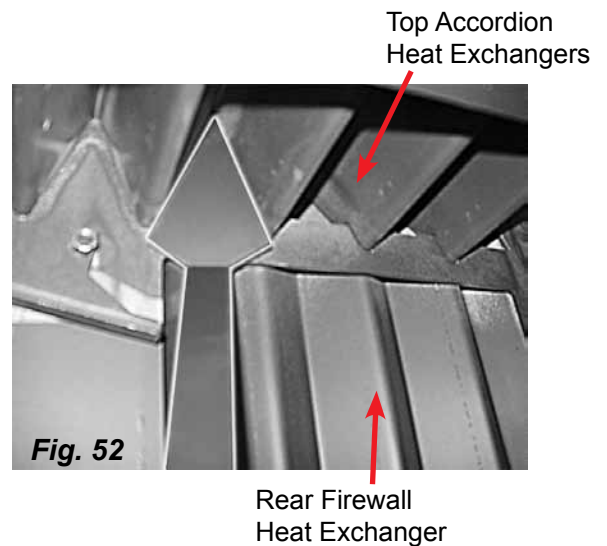

Advance Motor & Component Locations

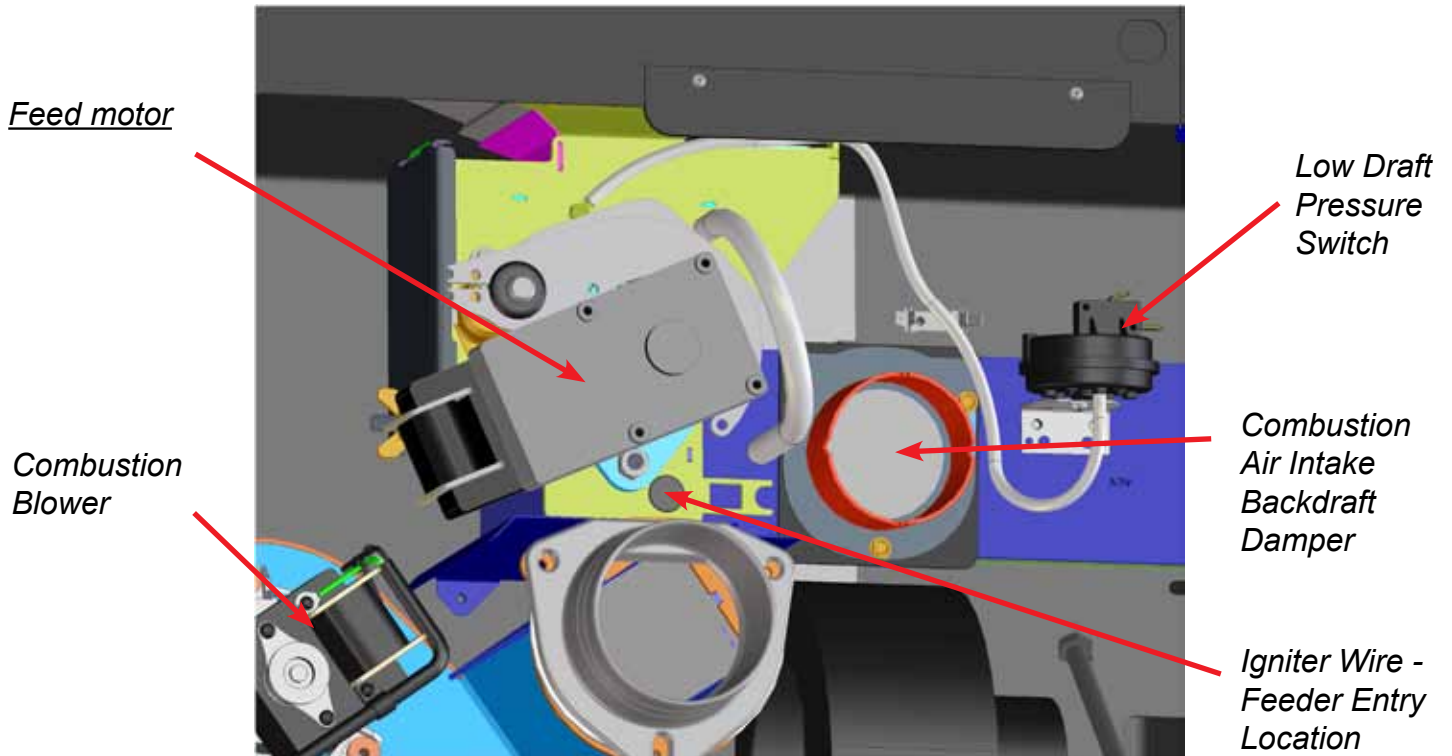

Advance Pellet Stove Safety Devices

The **Low Draft Pressure Switch** is a differential pressure switch that senses the negative pressure (draft) in the firebox. If the draft becomes too low for proper combustion, the switch opens, interrupting power to the feed motor and the igniter. This switch is connected into the AC (high voltage) wires.

The **Hopper Lid Position Switch** is located in the rear corner of the hopper opening. If the hopper lid is not closed properly, the switch opens, interrupting power to the feed motor and igniter circuits. This is to protect against reaching into the feed mechanism while in operation.

The **Control Board/ESP** combination is responsible for all high limit safety control. There are 2 high limits, one normal operation high limit and one backup high limit. The control has an automatic diagnostic circuit that continuously monitors the ESP and Room Sensor for faults. If a fault should occur, the control sends a status alert and at the same time the unit goes down to minimum feed/minimum burn as a safety condition.

Hopper Lid Position Switch

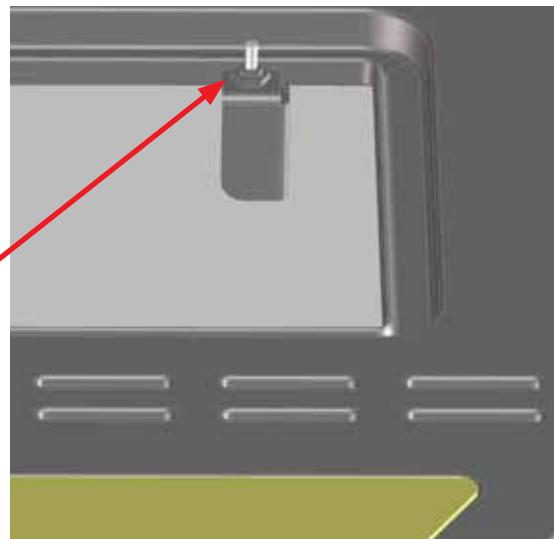

Trouble-Shooting

STOVE DOES NOT FEED

1. No fuel in hopper.
2. Firebox draft may be too low for sensing switch in feeder circuit to operate. **Check for closed doors**, loose or missing gasket on doors or hopper lid.
3. Hopper lid must contact the lid position switch.
4. Feed motor will not run until the ESP control senses a certain temperature. Maybe you did not put enough fuel or starting gel in the burn pot before manually lighting the fire.
5. Restriction in the hopper or feeder. Remove all fuel and examine. Clear the obstruction.
6. Feed motor has failed.

PARTIALLY BURNED PELLETS

1. Feed rate too high.
2. Poor air to fuel mixture. (Check burn pot clean-out cover and air intake).
3. Burn pot or heat exchanger tubes may need to be cleaned.
4. Combination of all the above.

5. **#6 status blink:** A 6 blink control board status indication is caused by poor or incomplete combustion. The circuit board has the ability to track the combustion through feed settings and ESP temperatures. When the control board has calculated poor or incomplete combustion, it will shut down the unit as a safety feature. (Poor or incomplete combustion is a contributor of creosote which may cause a chimney fire)

A 6 blink status may be caused by several things:

1. Blocked or partially blocked flue.
2. Blocked or partially blocked inlet air.
 - a. Backdraft damper on the inlet pipe may be stuck closed.
 - b. If outside air is installed, the inlet cover may be blocked.
3. The air chamber under the burnpot may be filled with fines and small bits of ash.
4. The holes in the burnpot may be getting filled with ash or carbon buildup.
5. Combustion blower fan blades may need cleaned.
6. Fuel restrictions as noted above.

SMOKE SMELL

Seal the vent pipe joints and connection to stove with silicone. The exhaust vent is the only part of the system that is under positive pressure.

FIRE HAS GONE OUT- Check for status light.

1. No fuel in hopper.
2. Draft is too low, blocked flue.
3. Something is restricting fuel flow.
4. Hopper lid not closed properly.
5. Feed motor or combustion blower has failed.

SMOKE IS VISIBLE COMING OUT OF VENT

1. Air-fuel ratio is too rich.
 - A. Feed rate too high.
 - B. Draft too low caused by a gasket leak.

LOW HEAT OUTPUT

1. Feed rate too low
2. Draft too low because of gasket leak.
3. Poor quality or damp pellets
4. Combination of 1 and 2.

Helpful Hints

Cleaning Burn Pot

Whenever your stove is not burning, take the opportunity to scrape the burn pot to remove carbon buildup. A vacuum cleaner is handy to remove the residue. Be sure the stove is cold if you use a vacuum.

Carbon buildup can be scraped loose with the fire burning using the special tool provided with your stove. Scrape the floor and sides of the burn pot. The carbon will be pushed out by the incoming fuel. Always wear gloves to do this.

Removing Ashes

Turn the Temp Dial to number 1 approximately 30 minutes before removing ashes. This will result in a cooler stove and ash pan.

Maximum Feed Adjuster settings are not needed in most cases. Operating in the normal range (#4) is recommended when maximum heat output is not required. The ESP prevents the stove from being over-fired.

Keep the stove free of dust and dirt.

Fuel

CAUTION! DO NOT USE FUELS THAT ARE NOT SPECIFIED FOR USE WITH THIS APPLIANCE. FUELS SUCH AS COAL OR CHARCOAL ARE KNOWN FOR PRODUCING HIGH LEVELS OF CARBON MONOXIDE WHEN BURNED. USE OF THESE OR SIMILAR FUELS CAN POSE A SERIOUS HEALTH HAZARD OR CAUSE DAMAGE TO THE APPLIANCE AND/OR YOUR HOME.

Complete fuel specifications are found on the next page.

Fuel Specifications

Fuel and Fuel Storage

Pellet fuel quality can fluctuate from manufacturer to manufacturer, and even from bag to bag.

Hearth & Home Technologies recommends using only fuel that is certified by the Pellet Fuels Institute (PFI).

Fuel Material

- Made from sawdust and/or other wood by-products
- Shelled field corn (when mixed with wood pellets)
- Source material typically determines ash content

Higher Ash Content Material

- Hardwoods with high mineral content
- Bark and leaves as source material
- “Standard” grade pellets, corn and other biomass

Lower Ash Content Material

- Softwood; pine, fir, etc.
- Materials with lower mineral content
- “Premium” grade pellets

Shelled field corn

- Must be 15% moisture content or less
- Must be clean and free of debris
- Must be mixed with wood pellets. (Up to 50%)
- Stalk parts, excessive fines and cob remnants may cause feed system jams or blockage

CAUTION! Do not burn fuel that contains an additive; (such as soybean oil)

- May cause hopper fire
- Damage to product may result

Read the list of ingredients on the packaging. If you are buying field corn, the only ingredient listed should be field corn.

WARNING! Risk of Chemical Poisoning!

Do **NOT** burn treated seed corn

- Chemical pesticides are harmful or fatal if swallowed
- Burning treated seed corn will void the product warranty

Clinkers

Minerals and other non-combustible materials, like sand, will turn into a hard glass-like substance when heated.

Trees from different areas will vary in mineral content. For this reason, some fuels will produce more clinkers than others.

Moisture

Always burn dry fuel. Burning fuel with high moisture content takes energy to dry and tends to cool the appliance thus, robbing heat from your home. Damp pellet fuel could turn back into sawdust which does not flow properly through the feed system.

Size

- Pellets are either 1/4 inch or 5/16 inch (6-8mm) in diameter
- Length should be no more than 1-1/2 inches (38mm)
- Pellet length can vary from lot to lot from the same manufacturer

Performance

- Higher ash content requires more frequent maintenance.
- “Premium” grade pellets will produce the highest heat output.
- Burning pellets longer than 1-1/2 inches (38mm) can cause inconsistent feeding and/or ignition.

We recommend that you buy fuel in multi-ton lots whenever possible. However, we do recommend trying different brands prior to purchasing multi-ton lots, to ensure your satisfaction.

CAUTION! Tested and approved for use with wood pellets and a mixture of shelled field corn and wood pellets ONLY. Burning of any other fuel will void your warranty.

When changing from wood pellets to a corn/pellet mixture, the FEED ADJUSTER will likely need adjusted to a lower setting. When under maximum demand, ensure there is no unburned fuel being pushed into the ash pan.

Storage

- Wood pellets should be left in their original sealed bag until ready to use, to prevent moisture.
- Shelled corn should be stored in a tightly sealed container to prevent moisture and to deter pests
- Do not store fuel within the specified clearance areas, or in a location that will interfere with routine cleaning and maintenance procedures.

CAUTION

Tested and approved for use with wood pellets and a mixture of shelled field corn and wood pellets ONLY. Burning of any other fuel will void your warranty.

NOTICE

Hearth & Home Technologies is not responsible for stove performance or extra maintenance required as a result of using fuel with higher ash or mineral content.

Specifications

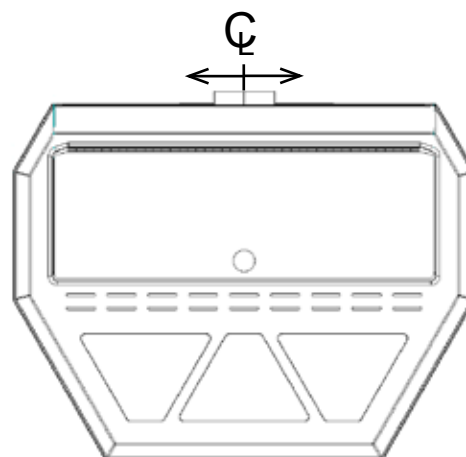
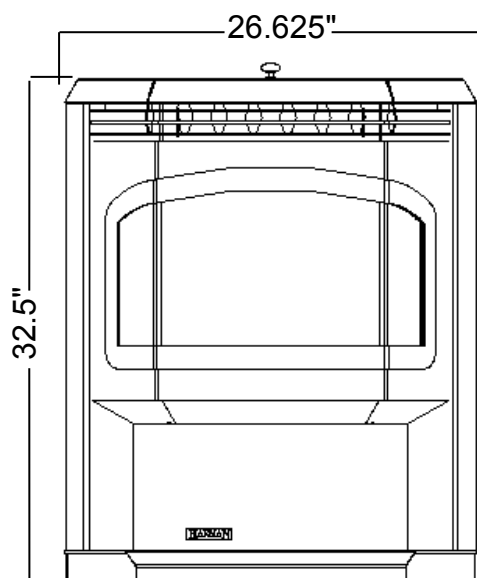
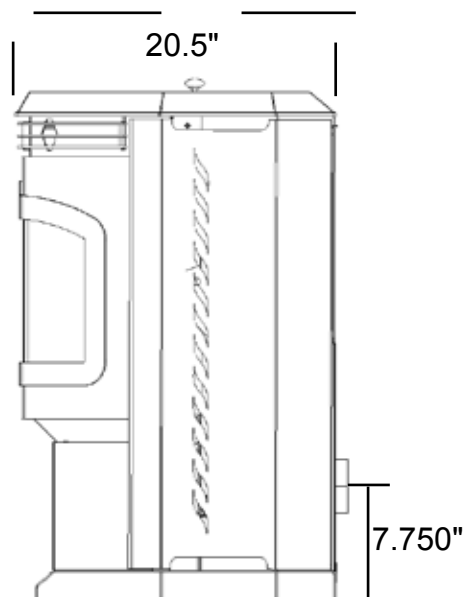
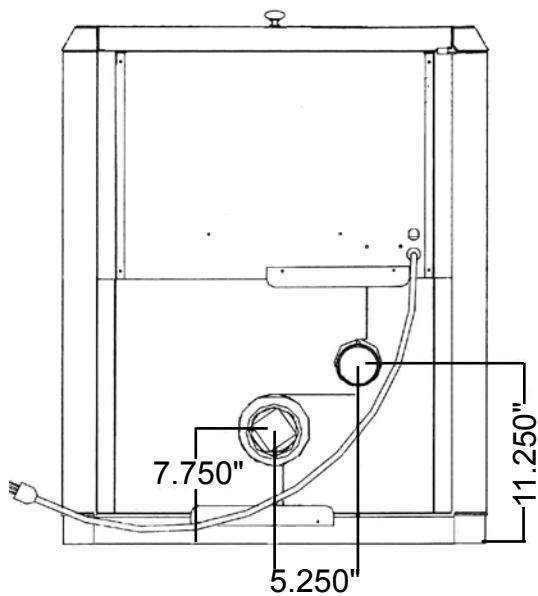

Weight	250 lbs.
Blower	135 cfm
Hopper Capacity	60 lbs.
Fuel	Wood Pellets or Corn/Pellet Mix
Outside Air Size	2 3/8 inches
Fuse Rating	6 amp
BTU Range	0 to 48,000
Feed Rate	1.0 lbs./hr. on minimum 6 lbs./ hr. on maximum
Flue Size	3 inch Pellet Vent Pipe
Maximum Wattage	480 Watts (Start cycle and test)
Start Cycle Wattage	340 Watts
Normal Run Wattage	275 Watts

Advance Wiring Diagram

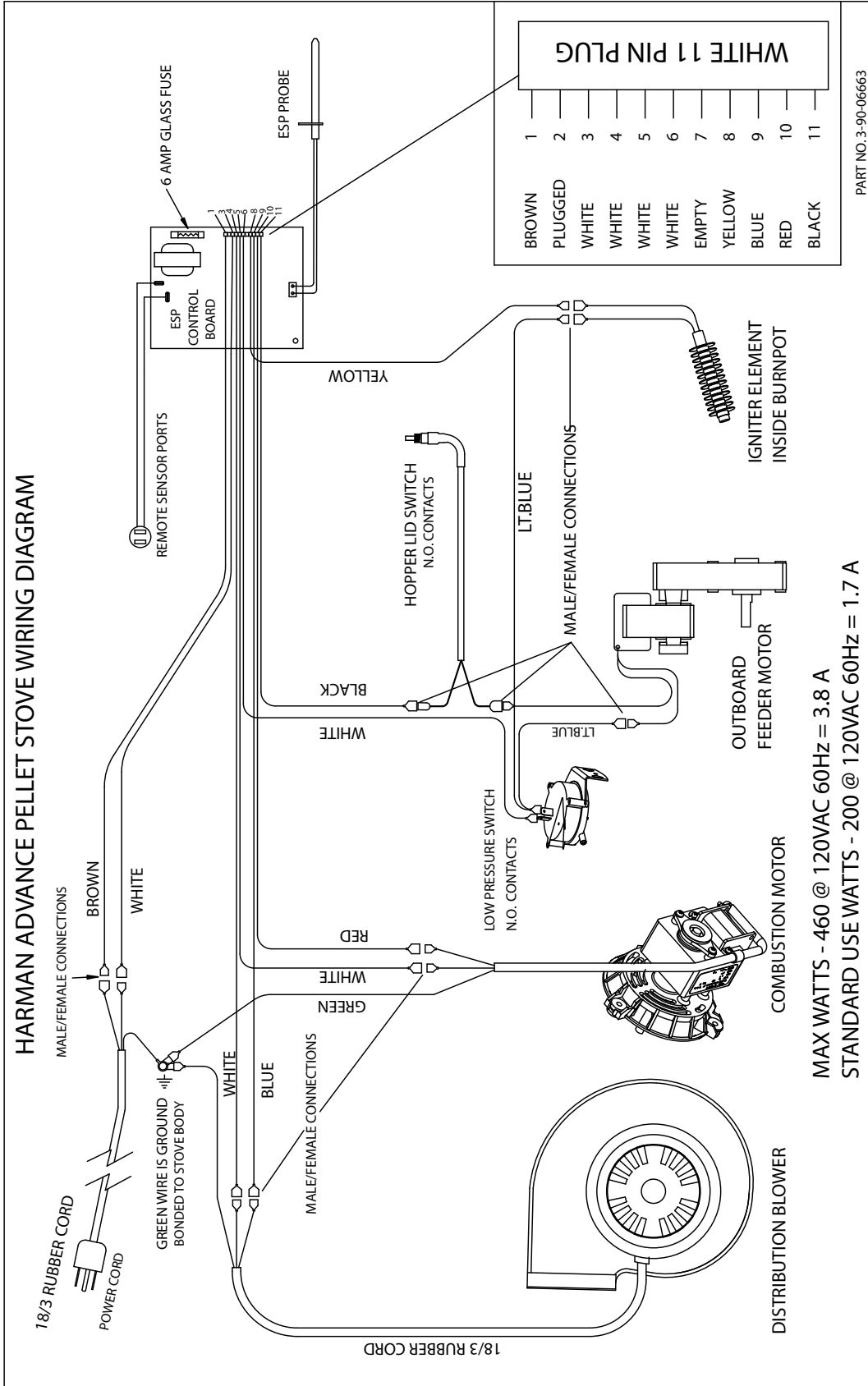

**Hearth & Home Technologies Inc.
LIMITED LIFETIME WARRANTY**

Hearth & Home Technologies Inc., on behalf of its hearth brands ("HHT"), extends the following warranty for HHT gas, wood, pellet, coal and electric hearth appliances that are purchased from an HHT authorized dealer.

WARRANTY COVERAGE:

HHT warrants to the original owner of the HHT appliance at the site of installation, and to any transferee taking ownership of the appliance at the site of installation within two years following the date of original purchase, that the HHT appliance will be free from defects in materials and workmanship at the time of manufacture. After installation, if covered components manufactured by HHT are found to be defective in materials or workmanship during the applicable warranty period, HHT will, at its option, repair or replace the covered components. HHT, at its own discretion, may fully discharge all of its obligations under such warranties by replacing the product itself or refunding the verified purchase price of the product itself. The maximum amount recoverable under this warranty is limited to the purchase price of the product. This warranty is subject to conditions, exclusions and limitations as described below.

WARRANTY PERIOD:

Warranty coverage begins on the date of original purchase. In the case of new home construction, warranty coverage begins on the date of first occupancy of the dwelling or six months after the sale of the product by an independent, authorized HHT dealer/ distributor, whichever occurs earlier. The warranty shall commence no later than 24 months following the date of product shipment from HHT, regardless of the installation or occupancy date. The warranty period for parts and labor for covered components is produced in the following table.

The term "Limited Lifetime" in the table below is defined as: 20 years from the beginning date of warranty coverage for gas appliances, and 10 years from the beginning date of warranty coverage for wood, pellet, and coal appliances. These time periods reflect the minimum expected useful lives of the designated components under normal operating conditions.

Warranty Period		HHT Manufactured Appliances and Venting							Components Covered
Parts	Labor	Gas	Wood	Pellet	EPA Wood	Coal	Electric	Venting	
1 Year		X	X	X	X	X	X	X	All parts and material except as covered by Conditions, Exclusions, and Limitations listed
2 years				X	X	X			Igniters, electronic components, and glass
		X	X	X	X	X			Factory-installed blowers
				X					Molded refractory panels
3 years				X					Firepots and burnpots
5 years	1 year			X	X				Castings and baffles
7 years	3 years		X	X	X				Manifold tubes, HHT chimney and termination
10 years	1 year	X							Burners, logs and refractory
Limited Lifetime	3 years	X	X	X	X	X			Firebox and heat exchanger
90 Days		X	X	X	X	X	X	X	All replacement parts beyond warranty period

See conditions, exclusions, and limitations on next page.

WARRANTY CONDITIONS:

- This warranty only covers HHT appliances that are purchased through an HHT authorized dealer or distributor. A list of HHT authorized dealers is available on the HHT branded websites.
- This warranty is only valid while the HHT appliance remains at the site of original installation.
- Contact your installing dealer for warranty service. If the installing dealer is unable to provide necessary parts, contact the nearest HHT authorized dealer or supplier. Additional service fees may apply if you are seeking warranty service from a dealer other than the dealer from whom you originally purchased the product.
- Check with your dealer in advance for any costs to you when arranging a warranty call. Travel and shipping charges for parts are not covered by this warranty.

WARRANTY EXCLUSIONS:

This warranty does not cover the following:

- Changes in surface finishes as a result of normal use. As a heating appliance, some changes in color of interior and exterior surface finishes may occur. This is not a flaw and is not covered under warranty.
- Damage to printed, plated, or enameled surfaces caused by fingerprints, accidents, misuse, scratches, melted items, or other external sources and residues left on the plated surfaces from the use of abrasive cleaners or polishes.
- Repair or replacement of parts that are subject to normal wear and tear during the warranty period. These parts include: paint, wood, pellet and coal gaskets, firebricks, grates, flame guides, light bulbs, batteries and the discoloration of glass.
- Minor expansion, contraction, or movement of certain parts causing noise. These conditions are normal and complaints related to this noise are not covered by this warranty.
- Damages resulting from: (1) failure to install, operate, or maintain the appliance in accordance with the installation instructions, operating instructions, and listing agent identification label furnished with the appliance; (2) failure to install the appliance in accordance with local building codes; (3) shipping or improper handling; (4) improper operation, abuse, misuse, continued operation with damaged, corroded or failed components, accident, or improperly/incorrectly performed repairs; (5) environmental conditions, inadequate ventilation, negative pressure, or drafting caused by tightly sealed constructions, insufficient make-up air supply, or handling devices such as exhaust fans or forced air furnaces or other such causes; (6) use of fuels other than those specified in the operating instructions; (7) installation or use of components not supplied with the appliance or any other components not expressly authorized and approved by HHT; (8) modification of the appliance not expressly authorized and approved by HHT in writing; and/or (9) interruptions or fluctuations of electrical power supply to the appliance.
- Non-HHT venting components, hearth components or other accessories used in conjunction with the appliance.
- Any part of a pre-existing fireplace system in which an insert or a decorative gas appliance is installed.
- HHT's obligation under this warranty does not extend to the appliance's capability to heat the desired space. Information is provided to assist the consumer and the dealer in selecting the proper appliance for the application. Consideration must be given to appliance location and configuration, environmental conditions, insulation and air tightness of the structure.

This warranty is void if:

- The appliance has been over-fired or operated in atmospheres contaminated by chlorine, fluorine, or other damaging chemicals. Over-firing can be identified by, but not limited to, warped plates or tubes, rust colored cast iron, bubbling, cracking and discoloration of steel or enamel finishes.
- The appliance is subjected to prolonged periods of dampness or condensation.
- There is any damage to the appliance or other components due to water or weather damage which is the result of, but not limited to, improper chimney or venting installation.

LIMITATIONS OF LIABILITY:

- The owner's exclusive remedy and HHT's sole obligation under this warranty, under any other warranty, express or implied, or in contract, tort or otherwise, shall be limited to replacement, repair, or refund, as specified above. In no event will HHT be liable for any incidental or consequential damages caused by defects in the appliance. Some states do not allow exclusions or limitation of incidental or consequential damages, so these limitations may not apply to you. This warranty gives you specific rights; you may also have other rights, which vary from state to state. EXCEPT TO THE EXTENT PROVIDED BY LAW, HHT MAKES NO EXPRESS WARRANTIES OTHER THAN THE WARRANTY SPECIFIED HEREIN. THE DURATION OF ANY IMPLIED WARRANTY IS LIMITED TO DURATION OF THE EXPRESSED WARRANTY SPECIFIED ABOVE.

Retired Units

1-70-08730-2 (Charcoal) (Ending Manufacturing Date: June 2009)
 1-70-08730-3 (Goldenfire) (Ending Manufacturing Date: June 2009)
 1-70-08730-4 (Metallic Blue) (Ending Manufacturing Date Jan 2010)

1-70-08730-5 (Honey Glo) (Ending Manufacturing Date: June 2009)
 1-70-08730-10 (Mojave Red) (Ending Manufacturing Date Jan 2010)
 1-70-08730-12 (Forest Green) (Ending Manufacturing Date Jan 2010)

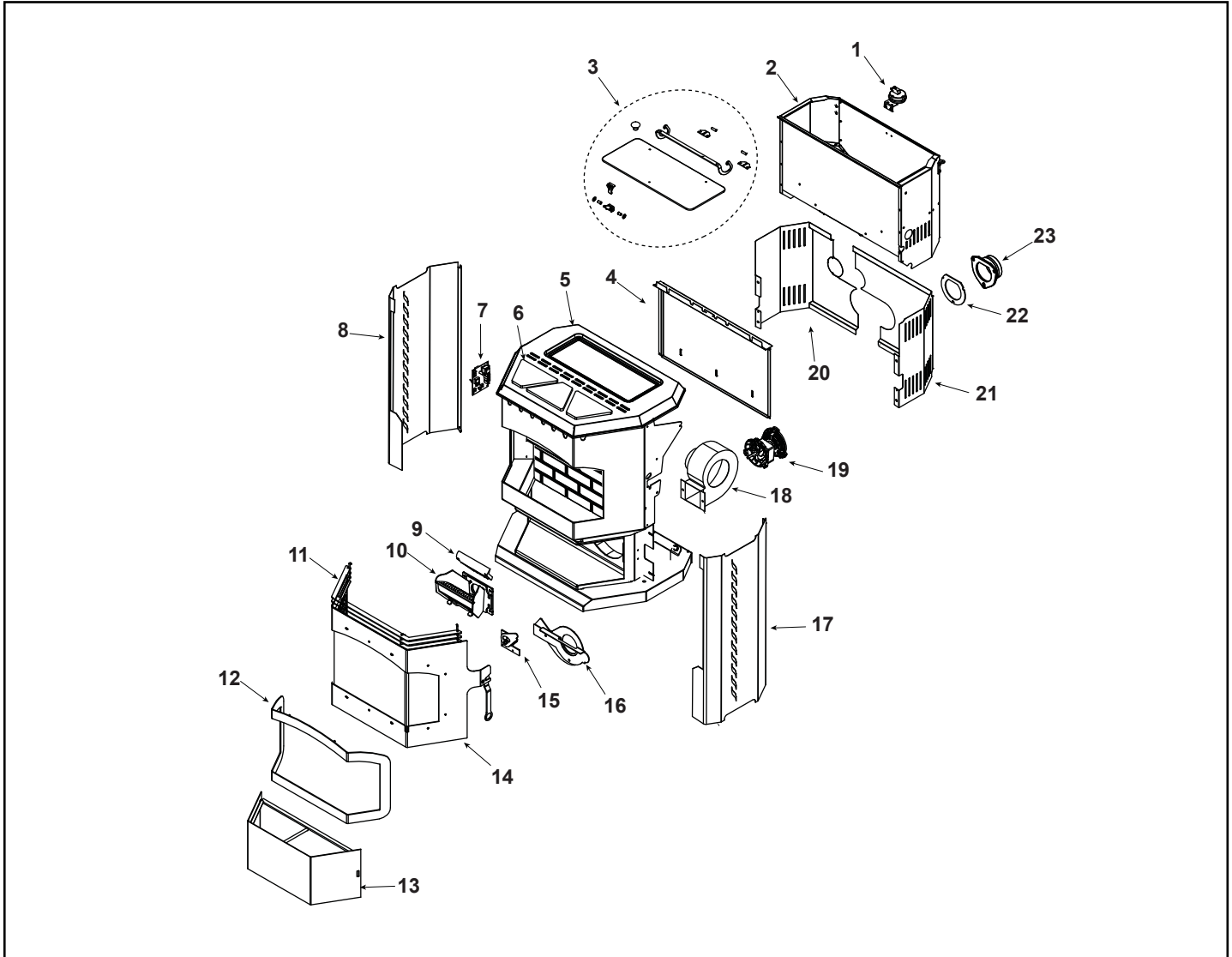

IMPORTANT: THIS IS DATED INFORMATION. When requesting service or replacement parts for your appliance please provide model number and serial number. All parts listed in this manual may be ordered from an authorized dealer.



Stocked at Depot

ITEM	DESCRIPTION	COMMENTS	PART NUMBER	
1	Differential Switch		3-20-6866	Y
2	UL Hopper Assembly	Pre 008360001	1-10-09731S	Y
		008360001 Thru 008362435/ Must also order Retrofit Switch kit**	1-10-09876A	Y
			1-00-232108**	Y
		Post 008362435	1-10-09876A	Y
	Gasket, Hopper Top		1-00-375501	Y
	Switch, Hopper, 48"	Post 008362469	3-20-232108	Y

Additional service parts on following page.

#3 Hopper Lid Assembly

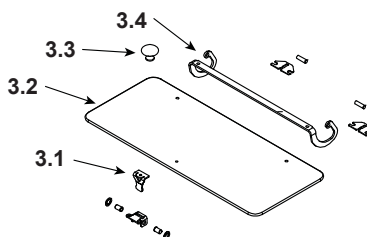

IMPORTANT: THIS IS DATED INFORMATION. When requesting service or replacement parts for your appliance please provide model number and serial number. All parts listed in this manual may be ordered from an authorized dealer.



Stocked at Depot

ITEM	DESCRIPTION	COMMENTS	PART NUMBER	
3	Hopper Lid Assembly			
3.1	Hopper Lid Latch (Male and Female)	2 Sets	1-00-0669697	Y
3.2	Hopper Lid		3-40-06693	Y
3.3	Hopper Knob	Gold	3-43-02000	
		Brushed Nickel	3-43-02000-8	
3.4	Hinge		2-00-06694	
	Screw Post Kit , Connects Hopper Lid to Hinge	Pkg of 20	1-00-129004	Y
4	Hopper Heat Shield Rev - A		2-00-06612B	
5	Top		4-00-08739P	
6	Tile Set	Cream	3-43-03000-1	
		No longer available	3-43-03000-2	
		Black	3-43-03000-3	
		No longer available	3-43-03000-4	
7	Circuit Board Studded w/Label		1-00-05886	Y
	6 Amp Fuse	Pkg of 5	3-20-49447-5	Y
	Control Board Knob/ D-shaft	25 Sets	1-00-015605	Y
8	Side Door - Left		2-00-06610-1P	
9	Flame Guide		3-00-06644	Y
10	Burn Pot		1-10-00675	Y
	Burn Pot Igniter		3-20-677200	Y
	Arrow Burn Pot Scraper	Pkg of 10	2-00-773850-10	
	Ceramic Insert Gasket		3-44-724114	Y
	Clean Out Cover	2 Sets	1-00-06623	Y
	Thumb Screw	Pkg of 10	3-31-782108-10	Y
	Ignitor Cradle, Holder, & Flat Bottom	3 Sets	1-00-06620	Y
11	Grill Weldment	Gold	3-43-06642-4	
		Brushed Stain	3-43-06642-7	
		Brushed Nickel	3-43-06642-8	
12	Frame	Gold	3-43-06613-4	
		Brushed Stain	3-43-06613-7	
		Brushed Nickel	3-43-06613-8	

Additional service parts on following page.

IMPORTANT: THIS IS DATED INFORMATION. When requesting service or replacement parts for your appliance please provide model number and serial number. All parts listed in this manual may be ordered from an authorized dealer.



**Stocked
at Depot**

ITEM	Description	COMMENTS	PART NUMBER	Stocked at Depot
13	Ash Pan Weldment		1-10-07581A	Y
	Ash Pan Gasket	30 Ft	1-00-00888	Y
14	Door Assembly		1-10-08612A	
	Gasket, Door, 1 1/2" x 7/16"	Qty 1 req	2-00-71611	Y
	Gasket, Glass	10 Ft	1-00-2312	Y
	Glass, Large Front		3-40-08728	Y
	Glass, Side		3-40-08729	Y
	Glass Clips	1 Set	1-00-06600	
15	Retainer Assembly for Combustion Blower cover		1-10-08553S	Y
16	Combustion Intake Weldment		1-10-07574W	Y
17	Side Door - Right		2-00-06610-2P	
18	Distribution Blower		3-21-22647	Y
19	Combustion Blower		3-21-08639	Y
	Fan Blade, 5" , Double Paddle		3-20-502221	Y
20	UL Feeder Hopper Rear Shield Left	Pre 008360001	2-00-06617P	Y
		Post 008360001	2-00-06788P	Y
21	UL Feeder Hopper Rear Shield Right	Pre 008360001	2-00-06616P	Y
		Post 008360001	2-00-06789B	Y
22	Pellet Tailpipe Gasket	Pkg of 5	1-00-07381	Y
23	Pellet Tailpipe Cast		3-00-247237	Y
	Diagnostic Display Meter		3-20-05401	
	Door Hinge Weldment	Qty 2 req	1-10-08735W	
	Draft Meter Assembly		1-00-00637	
	Harman Gold Label	Pkg of 5	3-90-08540-5	
	Harman Silver Label	Pkg of 5	3-90-04580-5	
	Hopper Muffler and Fitting	1 Set	1-00-18186618	Y
	Power Cord		3-20-39685	Y
	Room Sensor		3-20-00906	Y
	Spring Latch	Qty 2 req	3-31-00927	Y
	Wiring Harness		3-20-08727	Y
	Thermister Probe	Pre SN 008360001	3-20-11744	Y
		Post SN 008360001	3-20-00844	Y
	Touch up Paint	12 oz Can	3-42-1990	
	Thermostat Extension		3-20-00607	Y

Additional service parts on following page.

Pre Serial Number 008360001 Feeder Assembly

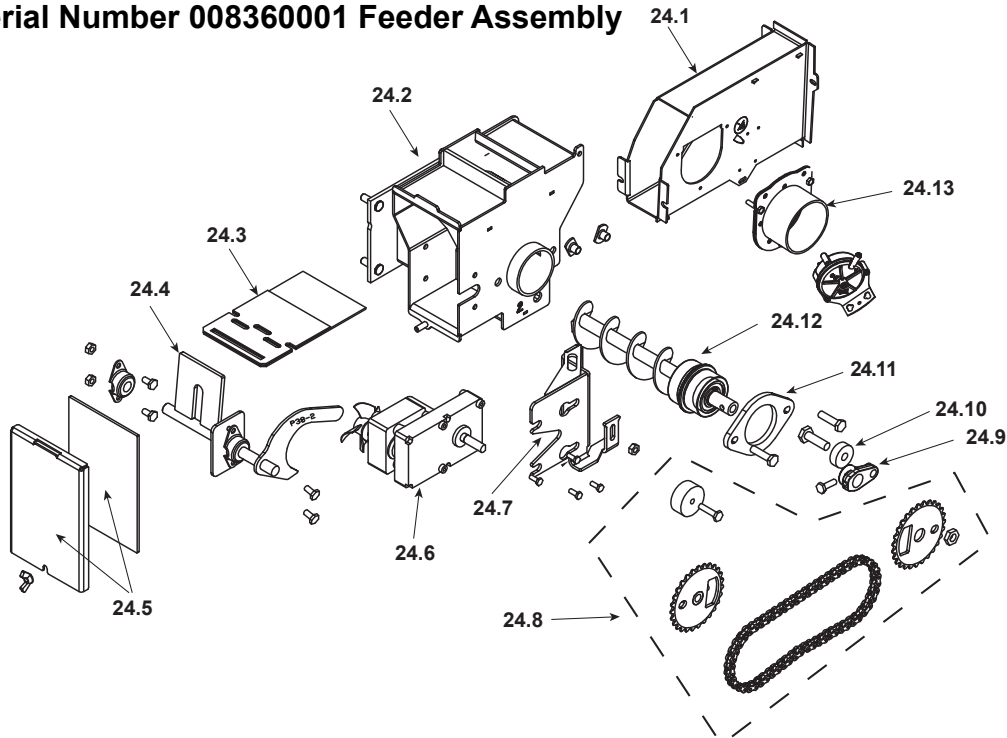

IMPORTANT: THIS IS DATED INFORMATION. When requesting service or replacement parts for your appliance please provide model number and serial number. All parts listed in this manual may be ordered from an authorized dealer.



**Stocked
at Depot**

ITEM	DESCRIPTION	COMMENTS	PART NUMBER	
24	UL Feeder Assembly	Pre 008360001	1-10-09775A	
24.1	Air Intake Weldment		1-10-06593W	
24.2	Feeder Weldment		1-10-677150	Y
24.3	Slide Plate Assembly		1-10-08037	Y
24.4	Pusher Arm Assembly		1-10-01530	Y
24.5	Feed Cover and Gasket	2 Sets	1-00-677152	Y
24.6	Gear Motor, 4 RPM		3-20-08752	Y
24.7	Bracket, Gear Motor		1-10-677005	Y
24.8	Sprocket Replacement Kit		1-00-06626	Y
	3/4 Feeder Tensioner		3-31-00075	
24.9	Cast Cam Block		3-00-00153	Y
24.10	Cam Bearing		3-31-3014	Y
24.11	Bearing Flange w/Hardware		1-00-04035	Y
24.12	Auger Assembly		3-50-00465	Y
24.13	Air Intake Damper Assembly		1-10-06466W	
	Gasket, Feeder, Air Intake	Pkg of 6	3-44-72224-6	Y
	Feeder Air Crossover Kit		1-00-67900	Y
	Feeder Repair Kit		1-00-677150	Y

Additional service parts on following page.

Post Serial Number 008360001 Feeder Assembly

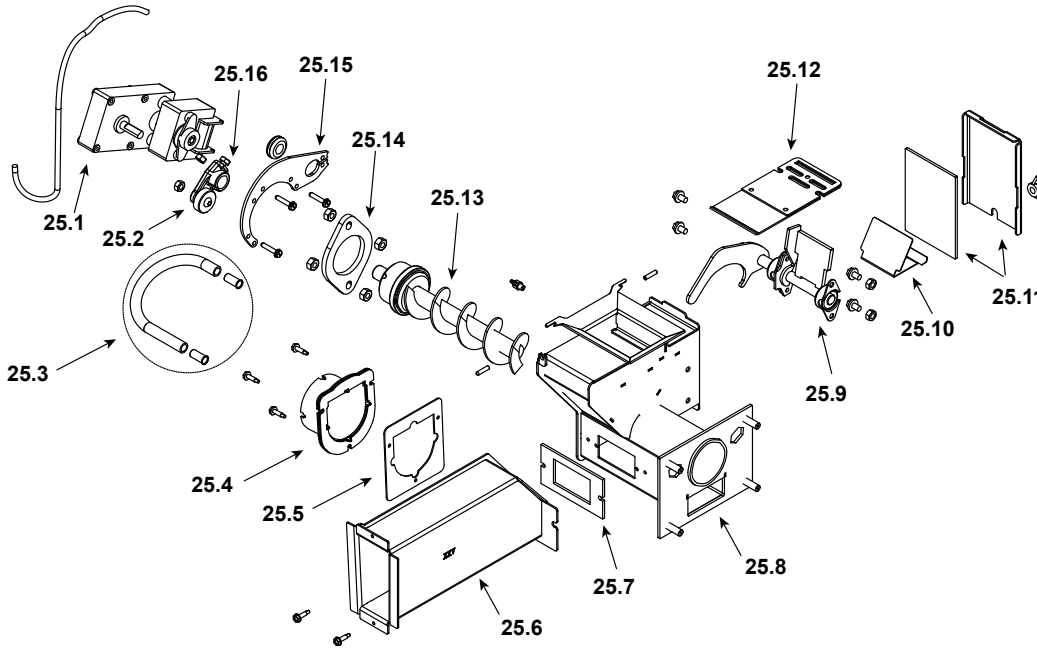

IMPORTANT: THIS IS DATED INFORMATION. When requesting service or replacement parts for your appliance please provide model number and serial number. All parts listed in this manual may be ordered from an authorized dealer.



**Stocked
at Depot**

ITEM	Description	COMMENTS	PART NUMBER	
25	UL Feeder Assembly	Post 008360001	1-10-09875A	
25.1	Pellet Feeder Gear Motor, 4 RPM		3-20-00677	Y
25.2	UL Feeder Cam Bearing		3-31-3014	Y
25.3	Feeder Air Crossover Kit		1-00-67900	Y
	9MM Silicone Tube		1-00-511427	Y
25.4	Pellet Air Intake Assembly		1-10-06810A	
25.5	Gasket Feeder Air Intake	Pkg of 6	3-44-72224-6	Y
25.6	UL Feeder Air Intake		1-10-677183	
25.7	Gasket Ultra Air Intake	Pkg of 10	3-44-677160-10	Y
25.8	Ultra Feeder Weldment		1-10-724132	Y
25.9	UL Feeder Pusher Arm		1-10-677131W	Y
25.10	Fines Deflector	No longer available	2-00-677138-10	
25.11	Gasket, UL Feeder Cover		1-00-677122	Y
25.12	Slide Plate Assembly		1-10-677121A	Y
25.13	UL Feeder Auger Assembly		3-50-00565	Y
25.14	Bearing Flange w/Hardware		1-00-04035	Y
25.15	UL Feeder Gear Motor Bracket w/Grommet		1-00-247406	Y
25.16	UL Feeder Cam Block		3-00-677154	Y
	Gasket, Hopper throat		3-44-677185	Y

Additional service parts on following page.

IMPORTANT: THIS IS DATED INFORMATION. When requesting service or replacement parts for your appliance please provide model number and serial number. All parts listed in this manual may be ordered from an authorized dealer.



**Stocked
at Depot**

ITEM	Description	COMMENTS	PART NUMBER	
<p>#26 Hardware Kit</p> <div style="text-align: center;"> </div>				
26.1	Latch Adjuster, Spring holder, & Door latch	1 Set	1-00-06770	
26.2	Screw, 1/4-20 x 3/4" Grade 5 Zinc Plated Hex	Pkg of 100	3-30-1112-100	Y
26.3	Screw, 1/4-20 x 7/8 Grade 5 Zinc Hex Cap	Pkg of 50	3-30-1114-50	Y
26.4	Bushing 3/8 OD x 1/4 OAL	Pkg of 5	3-50-00058-5	Y
26.5	Latch Bushing 3/8 OD x 5/16 OAL	Pkg of 5	3-50-08288-5	Y
26.6	Nut, 1/4"-20 Zinc Plated Finished Hex	Pkg of 100	3-30-8004-100	Y
<p>#27 Firebox Assembly</p> <div style="text-align: center;"> </div>				
27.1	Firebox Heat Exchanger Cover	Qty. 2 Req.	2-00-06692B	
27.2	Heat Exchanger Cleanout Cover Latch		2-00-06698B	
27.3	Baffle Plate	Qty. 2 Req.	2-00-06632L	
27.4	Cast Brick Panel		3-00-06641	Y
27.5	Log Bracket		1-00-06677	
27.6	Burner Protector Left		2-00-06631-1B	
27.7	Burner Protector Right		2-00-06631-2B	

Addendum for Burning Corn and Pellet Fuel Mixture

Harman pellet burning, free-standing stoves and inserts have been tested to ASTM E1509 for burning shelled corn in a mixture with wood pellets. The listing approves up to a 50% corn and 50% pellet mixture. Different mixtures of corn will have distinctively different burn characteristics depending upon moisture content and variety. The operator should closely monitor the stove's operation when burning a new corn/pellet mixture or a different variety of corn, and make any necessary adjustments to feed rate. Since corn is typically higher in ash and moisture content, cleaning and ash removal will be needed more frequently.

Operation in Stove Temp mode

Set feed adjuster to # 3. Set temperature knob to #3, Turn mode selector knob onto "Stove Temp" mode. After the fire has lit, watch that the fuel does not feed too fast that it pushes the red glowing fuel bed off of the burn pot grate. If it does, lower the feed adjuster setting or use a lower percentage of corn in the mixture. After the stove has burned for 10 minutes and the entire fuel bed is burning, the feed adjuster and temperature knobs may be adjusted for higher heat output if desired. Maximum feed has been reached when the fire bed is about ½ to 1 inch from the end of the burn pot. Settings will vary with different types, moisture levels and mix ratios of corn. If you are having difficulty burning a 50% corn / 50% wood pellet mixture, try a lower percentage of corn.

Operation in Room Temp mode

Set feed adjuster to # 2 or # 3. Set temperature knob to desired amount. Turn mode selector knob onto "Room Temp" mode. After the fire has lit, watch that the fuel does not feed too fast that it pushes the red glowing fuel bed off of the burn pot grate. After the stove has burned for 10 minutes and the entire fuel bed is burning, the feed adjuster may be set to a higher output level if desired. Maximum feed has been reached when the fire bed is about ½ to 1 inch from the end of the burn pot. It is recommended that after burning at the desired settings, turn the stove off and allow it to cool, then turn it back on in "Room Temp" mode and watch the stove restart and verify correct operation. Settings will vary with different types, moisture levels and mix ratios of corn. If you are having difficulty burning a 50% corn 50% wood pellet mixture, try a lower percentage of corn.

Changes to Maintenance Schedule

Wood pellets average around 6% moisture content or less. Corn will be 14 or 15% moisture. With more moisture in the fuel, more maintenance will be incurred. Burn pot scraping may need to be done once per day. The ash pan will fill more quickly and may need emptied weekly. Most importantly, remove the burn pot cleanout cover weekly to clean the air passage and the igniter element. Excessive buildup on the igniter may lead to shortened igniter life.

Venting Consideration: Check with your venting manufacturer regarding possible exclusions when a mixture of corn and pellets is burned.

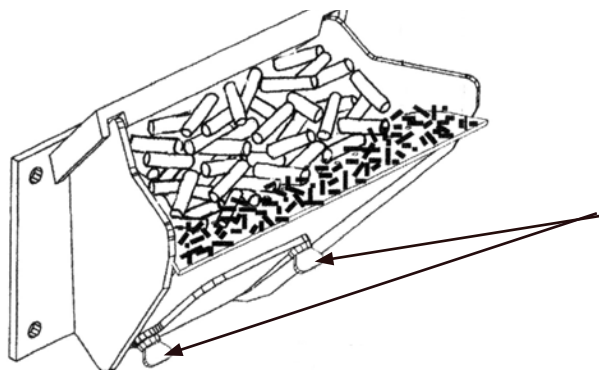

Loosen these two wing screws for access to clean the air passage and igniter.

Addendum

Minimizing Smoke During Loss of Power Using Battery Back-up

Harman™ strongly recommends installing battery back-up to minimize entry of smoke into the room in the event of power loss.

Your pellet/biomass burning appliance relies on a combustion blower to remove exhaust. A power failure will cause the combustion blower to stop. This may lead to exhaust seeping into the room. Vertical rise in the venting may provide natural draft. It is, however, no guarantee against leakage.

There are two Harman™ approved battery back-up options for your appliance:

Uninterruptible Power Supply (UPS) UPS battery back-ups are available online or at computer and office equipment stores. Your Harman™ appliance with Rev E or later software available beginning in November 2010 may be plugged directly into a Harman™ approved UPS:

- The APC (American Power Conversion) model #BE750G and the TrippLite model INTERNET750U are tested and approved. Other brands or models may not be compatible.

When power is lost, a fully charged UPS will power a safe, combustion blower only shut-down. Your appliance will pulse the blower every few seconds to clear exhaust until the fire is out. **NOTE: The UPS provides safe shut-down only. It is not intended for continued operation.**

Your appliance will recognize when power is restored. What happens depends on ESP temperature and whether it is equipped with automatic ignition:

- In **“Automatic” setting**, units equipped with automatic ignition will respond to the set point and ESP temperature and resume normal operation.
- In **“Manual” setting** or for units without automatic ignition:
 - If the ESP is cool, the appliance will remain shut down.
 - If the fire is out and the ESP is still warm, the feeder may restart. Since the fire is out, the ESP temperature will not rise. The unit will then shut-down, and may flash a six-blink status error. (See *ESP error codes*)
 - If the fire is still burning, it will resume normal operation.

Contact your dealer if you have questions about UPS compatibility with your appliance.

Harman Surefire 512H Battery Back-up The 512H connects to a 12 volt deep cycle battery that will run your appliance for up to eight (8) hours. It includes a trickle charge feature that keeps your battery charged when power is available. **NOTE: If the power is out for longer than battery life, smoke leakage may still occur unless your stove has been safely shut down.**

CAUTION! Always keep appliance doors and hopper lid closed and latched during operation and during power failures to minimize risk of smoke or burn-back.

CAUTION! Use only Harman™ approved battery back-up devices. Other products may not operate properly, can create unsafe conditions or damage your appliance.

HARMAN™

BUILT TO A STANDARD, NOT A PRICE

Proudly Printed On 100% Recycled Paper

